



# Contents

Preface .....	5
Revision.....	5
Copyright Notice.....	5
Acknowledgement.....	5
Disclaimer .....	5
Declaration of Conformity .....	5
Product Warranty Statement .....	6
Technical Support and Assistance .....	8
Conventions Used in this Manual.....	8
Safety Precautions .....	9
Ordering information.....	10
Chapter 1 Product Introductions .....	11
1.1 Overview.....	12
1.2 Highlights.....	12
1.3 Product Pictures .....	14
1.4 Key Features .....	14
1.5 Hardware Specification .....	15
1.6 System I/O .....	19
1.7 Mechanical Dimension .....	21
Chapter 2 Switches & Connectors .....	22
2.1 Location of Switches and Connectors .....	23
2.1.1 Top View .....	23
2.1.2 Bottom View.....	23
2.2 Switches and Connectors List.....	24
2.3 Definition of Switches and Connectors .....	25
Chapter 3 System Setup.....	31
3.1 Removing Top Cover.....	32
3.2 Installing SO-DIMM.....	34
3.3 Installing Mini-PCIe Card .....	35
3.4 Installing Antenna.....	36
3.5 Installing the Thermal Pad.....	38
3.6 Assembling Top Cover .....	39
3.7 Installing SATA Hard Drives at Front Panel.....	41
3.8 Installing SIM Card.....	43
3.9 Installing Wall Mount .....	44
3.10 VESA Mount .....	46
3.11 Connecting to Power Supply.....	47
Chapter 4 BIOS Setup.....	48
4.1 BIOS Introduction .....	49

4.2 Main Setup .....	50
4.3 Advanced Setup.....	51
4.3.1 CPU Configuration .....	51
4.3.2 PCH-FW Configuration.....	52
4.3.3 Trusted Computing.....	53
4.3.4 ACPI Settings.....	53
4.3.5 F81866 Super IO Configuration .....	54
4.3.6 Hardware Monitor.....	55
4.3.7 S5 RTC Wake Settings .....	56
4.3.8 Serial Port Console Redirection .....	56
4.3.9 USB Configuration .....	57
4.3.10 CSM Configuration.....	57
4.3.11 Network Stack Configuration .....	58
4.4 Chipset Setup.....	59
4.4.1 System Agent (SA) Configuration .....	59
4.4.2 PCH-IO Configuration .....	61
4.5 Security Setup.....	64
4.5.1 Administrator Password .....	64
4.5.2 User Password .....	64
4.5.3 Security Boot .....	64
4.6 Boot Setup .....	65
4.6.1 Setup Prompt Timeout [1].....	65
4.6.2 Bootup NumLock State [Off] .....	65
4.6.3 Quiet Boot [Disabled] .....	65
4.6.4 Fast Boot [Disabled].....	65
4.7 Save & Exit.....	66
4.7.1 Save Changes and Exit .....	66
4.7.2 Discard Changes and Exit.....	66
4.7.3 Save Changes and Reset .....	66
4.7.4 Discard Changes and Reset.....	66
4.7.5 Save Changes .....	66
4.7.6 Discard Changes.....	66
4.7.7 Restore Defaults .....	66
4.7.8 Save as User Defaults .....	66
4.7.9 Restore User Defaults.....	66
Chapter 5 Product Application.....	67
5.1 Digital I/O (DIO) application .....	68
5.1.1 Digital I/O Programming Guide .....	68
5.2 DIO Hardware Specification.....	77
5.2.1 DIO Connector Definition .....	78
Chapter 6 Optional Modules & Accessories .....	80

6.1 Optional Module Pin Definition & Settings .....	81
6.1.1 CMI-M12LAN01-R12/UB1510-R10 Module .....	81
6.1.2 CMI-XM12LAN01-R10/UB1510-R10 Module .....	81
6.1.3 CMI-10GLAN04-R10/UB1528-R10 Module .....	82
6.1.4 CMI-COM05-R10/UB1503-R10 Module .....	83
6.1.5 CFM-IGN102 Module.....	84
6.2 Installing High Speed CMI Module .....	85
6.2.1 CMI-LAN01-R12/UB1512-R10 Module.....	85
6.2.2 CMI-M12LAN01-R12/UB1510-R10 Module .....	86
6.2.3 CMI-XM12LAN01-R10/UB1510-R10 Module .....	88
6.2.4 CMI-10GLAN04-R10/UB1528-R10 Module .....	91
6.3 Installing Low Speed CMI Module .....	94
6.3.1 CMI-DIO05-R10/UB1518-R10 Module .....	94
6.3.2 CMI-COM05-R10/UB1503-R10 Module .....	95
6.4 Installing CFM Module.....	98
6.4.1 CFM-PoE06-R10 Module .....	98
6.4.2 CFM-IGN102 Module.....	101
6.5 Installing MEC Module.....	102
6.5.1 MEC-LAN-M102-30/UB1511-R10 Module.....	102
6.5.2 MEC-COM-M212-TDB9/ UB1503-R10 Module .....	105
6.6 Installing External FAN.....	108
6.6.1 FAN-EX103 .....	108
6.7 Installing DIN-Rail Mount Kit .....	110
6.7.1 DINRAIL-R10 .....	110
6.8 Installing Side Mount Kit.....	111
6.8.1 SIDE01.....	111

# Preface

## Revision

Revision	Description	Date
1.00	First Release	2021/11/15
1.01	Correction Made	2022/02/25
1.02	Correction Made	2022/05/31
1.03	Correction Made	2022/12/30
1.04	Correction Made	2023/04/14
1.05	Correction Made	2023/07/31

## Copyright Notice

© 2021 by Cincoze Co., Ltd. All rights are reserved. No parts of this manual may be copied, modified, or reproduced in any form or by any means for commercial use without the prior written permission of Cincoze Co., Ltd. All information and specification provided in this manual are for reference only and remain subject to change without prior notice.

## Acknowledgement

Cincoze is a registered trademark of Cincoze Co., Ltd. All registered trademarks and product names mentioned herein are used for identification purposes only and may be trademarks and/or registered trademarks of their respective owners.

## Disclaimer

This manual is intended to be used as a practical and informative guide only and is subject to change without notice. It does not represent a commitment on the part of Cincoze. This product might include unintentional technical or typographical errors. Changes are periodically made to the information herein to correct such errors, and these changes are incorporated into new editions of the publication.

## Declaration of Conformity



FCC

This equipment has been tested and found to comply with the limits for a Class A digital device, pursuant to Part 15 of the FCC Rules. These limits are designed to provide reasonable protection against harmful interference when the equipment is operated in a commercial environment. This equipment generates, uses, and can radiate radio frequency energy and, if not installed and used in accordance with the instruction manual, may cause harmful interference to radio communications.

Operation of this equipment in a residential area is likely to cause harmful interference in which case the user will be required to correct the interference at his own expense.



#### **CE**

The product(s) described in this manual complies with all application European Union (CE) directives if it has a CE marking. For computer systems to remain CE compliant, only CE-compliant parts may be used. Maintaining CE compliance also requires proper cable and cabling techniques.



#### **E-Mark**

The "E" mark is based on ECE regulations issued by the Economic Commission for Europe. It is an organizational part of the UN and the members are EU countries and many others. Therefore, the acceptance of approved components is much broader, especially in the eastern part of Europe. It is necessary to confirm whether a particular country has accepted (signed) the application of an ECE-regulation; as the application it is not mandatory for the countries.

## **Product Warranty Statement**

### **Warranty**

Cincoze products are warranted by Cincoze Co., Ltd. to be free from defect in materials and workmanship for 2 years from the date of purchase by the original purchaser. During the warranty period, we shall, at our option, either repair or replace any product that proves to be defective under normal operation. Defects, malfunctions, or failures of the warranted product caused by damage resulting from natural disasters (such as by lightening, flood, earthquake, etc.), environmental and atmospheric disturbances, other external forces such as power line disturbances, plugging the board in under power, or incorrect cabling, and damage caused by misuse, abuse, and unauthorized alteration or repair, and the product in question is either software, or an expendable item (such as a fuse, battery, etc.), are not warranted.

## **RMA**

Before sending your product in, you will need to fill in Cincoze RMA Request Form and obtain an RMA number from us. Our staff is available at any time to provide you with the most friendly and immediate service.

### **■ RMA Instruction**

- Customers must fill in Cincoze Return Merchandise Authorization (RMA) Request Form and obtain an RMA number prior to returning a defective product to Cincoze for service.
- Customers must collect all the information about the problems encountered and note anything abnormal and describe the problems on the “Cincoze Service Form” for the RMA number apply process.
- Charges may be incurred for certain repairs. Cincoze will charge for repairs to products whose warranty period has expired. Cincoze will also charge for repairs to products if the damage resulted from acts of God, environmental or atmospheric disturbances, or other external forces through misuse, abuse, or unauthorized alteration or repair. If charges will be incurred for a repair, Cincoze lists all charges, and will wait for customer’s approval before performing the repair.
- Customers agree to ensure the product or assume the risk of loss or damage during transit, to prepay shipping charges, and to use the original shipping container or equivalent.
- Customers can be sent back the faulty products with or without accessories (manuals, cable, etc.) and any components from the system. If the components were suspected as part of the problems, please note clearly which components are included. Otherwise, Cincoze is not responsible for the devices/parts.
- Repaired items will be shipped along with a "Repair Report" detailing the findings and actions taken.

### **Limitation of Liability**

Cincoze’ liability arising out of the manufacture, sale, or supplying of the product and its use, whether based on warranty, contract, negligence, product liability, or otherwise, shall not exceed the original selling price of the product. The remedies provided herein are the customer’s sole and exclusive remedies. In no event shall Cincoze be liable for direct, indirect, special or consequential damages whether based on contract of any other legal theory.

## Technical Support and Assistance

1. Visit the Cincoze website at [www.cincoze.com](http://www.cincoze.com) where you can find the latest information about the product.
2. Contact your distributor or our technical support team or sales representative for technical support if you need additional assistance. Please have following information ready before you call:
  - Product name and serial number
  - Description of your peripheral attachments
  - Description of your software (operating system, version, application software, etc.)
  - A complete description of the problem
  - The exact wording of any error messages

## Conventions Used in this Manual



### WARNING

This indication alerts operators to an operation that, if not strictly observed, may result in severe injury.



### CAUTION

This indication alerts operators to an operation that, if not strictly observed, may result in safety hazards to personnel or damage to equipment.



### NOTE

This indication provides additional information to complete a task easily.



## Safety Precautions

Before installing and using this device, please note the following precautions.

1. Read these safety instructions carefully.
2. Keep this User's Manual for future reference.
3. Disconnect this equipment from any AC outlet before cleaning.
4. For plug-in equipment, the power outlet socket must be located near the equipment and must be easily accessible.
5. Keep this equipment away from humidity.
6. Put this equipment on a reliable surface during installation. Dropping it or letting it fall may cause damage.
7. Make sure the voltage of the power source is correct before connecting the equipment to the power outlet.
8. Use a power cord that has been approved for using with the product and that it matches the voltage and current marked on the product's electrical range label. The voltage and current rating of the cord must be greater than the voltage and current rating marked on the product.
9. Position the power cord so that people cannot step on it. Do not place anything over the power cord.
10. All cautions and warnings on the equipment should be noted.
11. If the equipment is not used for a long time, disconnect it from the power source to avoid damage by transient overvoltage.
12. Never pour any liquid into an opening. This may cause fire or electrical shock.
13. Never open the equipment. For safety reasons, the equipment should be opened only by qualified service personnel.

If one of the following situations arises, get the equipment checked by service personnel:

- The power cord or plug is damaged.
  - Liquid has penetrated into the equipment.
  - The equipment has been exposed to moisture.
  - The equipment does not work well, or you cannot get it work according to the user's manual.
  - The equipment has been dropped and damaged.
  - The equipment has obvious signs of breakage.
14. **CAUTION:** Danger of explosion if battery is incorrectly replaced. Replace only with the same or equivalent type recommended by the manufacturer.
  15. Equipment intended only for use in a RESTRICTED ACCESS AREA.

## Ordering information

Before installation, please ensure all the items listed in the following table are included in the package. Notify your sales representative if any of the above items are missing or damaged.

### Available Models

Model No.	Product Description
DI-1100-i3-R10	8th Generation Intel Core i3-8145UE High Performance, Compact and Modular Rugged Embedded Computer
DI-1100-i5-R10	8th Generation Intel Core i5-8365UE High Performance, Compact and Modular Rugged Embedded Computer
DI-1100-i7-R10	8th Generation Intel Core i7-8665UE High Performance, Compact and Modular Rugged Embedded Computer

### Package Checklist

DI-1100 Embedded System x1	Screw Pack x1
Wall Mount Kit x1	Power Terminal Block Connector x1
Remote Function Terminal Block Connector x 2	Fan Terminal Block Connector x 1
Heatsink Pack x1	



# **Chapter 1**

## **Product Introductions**

# 1.1 Overview

The DI-1100 packs high performance, lots of I/O ports, and expansion flexibility in a compact form factor. The DI-1100 is powered by an 8th Gen Intel® Core™ U-Series processor (Whiskey Lake) with ultra-low 15W TDP yet delivering uncompromised performance. The DI-1100 shines because it fits multiple I/Os and other expansion options into a very compact chassis, making it the perfect high-performance rugged embedded computer for space-constrained environments. The DI-1100 is ideal for industrial applications, logistics and warehousing, transportation, security and surveillance, IoT deployments, and other applications.

# 1.2 Highlights



**15W TDP CPU DESIGN**

## Compact Form Factor

The DI-1100 has a small form factor, measuring only 203 mm (W) x 142 mm (D) x 66.8 mm (H). This compact size makes the DI-1100 easy to install anywhere you can imagine, especially in today's space-limited IoT applications, ranging from mobile equipment such as Automated Guided Vehicles (AGVs) and Autonomous Mobile Robots (AMRs) to vehicles and the small cabinets in factories.

## High Performance and Power Saving



The DI-1100 has options for an 8th Gen Intel® Core™ U i7, i5, or i3 processor, powered by four cores and eight threads, delivering extraordinary performance and responsiveness to complete computationally intensive tasks more quickly. The processing architecture fulfills the need for increased graphics and computation performance while providing the headroom to consolidate data and applications for IoT deployment. Topped off with a 15W TDP CPU, it's ideal for maximizing the battery life of mobile machinery.

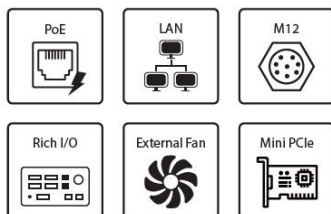

## Various Industrial I/O and Functionalities

The DI-1100's compact design doesn't sacrifice I/O and functionality. The DI-1100 includes 2x GbE LAN, 4x USB 3.2, 2x USB 2.0, and 2x RS232/422/485 to connect high-speed and legacy devices. The DI-1100 also supports 2x full-size Mini PCIe sockets for wireless connectivity as well as 2x SIM card slots for cellular network redundancy to ensure uninterrupted data transmission. In addition, it offers an external fan for additional cooling when using high-watt peripherals like cameras thru PoE.

## Exclusive Expansion Capabilities

The DI-1100 provides modular expansion through Combined Multiple I/O (CMI) and Control Function Module (CFM) and can be configured for further I/O and function customization. This flexibility allows integrators to quickly configure the system and rapidly deploy to the market. The CMI modules include extra LAN, 10GbLAN, M12 connections (A- and X-coded), and various I/O interfaces, while CFM provides power ignition sensing or PoE functionality.



## Flexible Mounting

Multiple mounting methods are ready for use in various industrial environments, including wall, side, DIN-rail, and VESA mountings. These mounting options help integrators quickly and easily mount the DI-1100 anywhere, whether on the field side, cabinets, or inside of other equipment.

## Robust Design with Industry Certifications

The DI-1100 is engineered with a robust design to withstand extreme environments. It features a wide operating temperature range of -40 to 70°C, wide-range voltage input of 9 to 48 VDC, over-voltage protection, over-current protection, and ESD protection. The DI-1100 passed the tests to ensure compliance with MIL-STD-810G, E-mark, and EN50155 (EN 50121-3-2 only).



## 1.3 Product Pictures



Front



Rear

## 1.4 Key Features

- Onboard Intel® 8th Gen. Core™ U i7/i5/i3 Processor (TDP 15W)
- 1x 2.5" front accessible SATA HDD bay for quick access and 1x mSATA socket
- 2x full-size Mini PCIe sockets for module expansion
- 2x front accessible SIM card slots for signal redundancy
- Optional CMI modules (2x 10 GbE LAN, M12 A-coded, or M12 X-coded)
- Optional CFM modules (power ignition sensing, or 4x PoE)
- Wide operating temperature -40°C to 70°C
- MIL-STD-810G, E-mark and EN50155 (EN 50121-3-2 only) certified

# 1.5 Hardware Specification

## System

<b>Processor</b>	<ul style="list-style-type: none"><li>• Onboard 8th Intel® Core™ U Processors (Whiskey Lake)<ul style="list-style-type: none"><li>- Intel® Core™ i7-8665UE Quad Core Processor (8M Cache, up to 4.4 GHz, 15W)</li><li>- Intel® Core™ i5-8365UE Quad Core Processor (6M Cache, up to 4.10 GHz, 15W)</li><li>- Intel® Core™ i3-8145UE Dual Core Processor (4M Cache, up to 3.90 GHz, 15W)</li></ul></li></ul>
<b>Memory</b>	<ul style="list-style-type: none"><li>• 1x DDR4 SO-DIMM Socket, Support Up to 2400MHz 32 GB (Un-buffered and non-ECC)</li></ul>
<b>BIOS</b>	<ul style="list-style-type: none"><li>• AMI BIOS</li></ul>
<b>Graphics</b>	
<b>Graphics Engine</b>	<ul style="list-style-type: none"><li>• Integrated Intel® UHD Graphics 620</li></ul>
<b>Maximum Display Output</b>	<ul style="list-style-type: none"><li>• Supports Triple Independent Display</li></ul>
<b>HDMI</b>	<ul style="list-style-type: none"><li>• 1x HDMI Connector (4096 x 2304@60Hz)</li></ul>
<b>DP</b>	<ul style="list-style-type: none"><li>• 1x DisplayPort Connector (4096 x 2304@60Hz)</li></ul>
<b>VGA</b>	<ul style="list-style-type: none"><li>• 1x VGA Connector (1920 x 1200 @60Hz)</li></ul>
<b>Audio</b>	
<b>Audio Codec</b>	<ul style="list-style-type: none"><li>• Realtek® ALC888, High Definition Audio</li></ul>
<b>Line-out</b>	<ul style="list-style-type: none"><li>• 1x Line-out, Phone Jack 3.5mm</li></ul>
<b>Mic-in</b>	<ul style="list-style-type: none"><li>• 1x Mic-in, Phone Jack 3.5mm</li></ul>
<b>I/O</b>	
<b>LAN</b>	<ul style="list-style-type: none"><li>• 2x GbE LAN, RJ45<ul style="list-style-type: none"><li>- GbE1: Intel® I219</li><li>- GbE2: Intel® I210</li></ul></li></ul>
<b>COM</b>	<ul style="list-style-type: none"><li>• 2x RS-232/422/485 with Auto Flow Control (Supports 5V/12V), DB9</li></ul>
<b>USB</b>	<ul style="list-style-type: none"><li>• 2x 10 Gbps USB 3.2 Gen2, Type A</li><li>• 2x 5 Gbps USB 3.2 Gen1, Type A</li><li>• 2x 480 Mbps USB 2.0, Type A</li></ul>
<b>PS/2</b>	<ul style="list-style-type: none"><li>• 1x PS/2, 6 Pin Mini-DIN Female Connector</li></ul>

<b>Storage</b>	
<b>SSD/HDD</b>	<ul style="list-style-type: none"> <li>• 1x 2.5" Front Accessible SATA HDD/SSD Bay (SATA 3.0)</li> </ul>
<b>mSATA</b>	<ul style="list-style-type: none"> <li>• 1x mSATA Socket (SATA 3.0, shared by Mini-PCIe socket)</li> </ul>
<b>RAID</b>	<ul style="list-style-type: none"> <li>• Support RAID 0/1</li> </ul>
<b>Expansion</b>	
<b>Mini PCI Express</b>	<ul style="list-style-type: none"> <li>• 2x Full-size Mini-PCIe Socket</li> </ul>
<b>SIM Socket</b>	<ul style="list-style-type: none"> <li>• 2x SIM Socket</li> </ul>
<b>CMI (Combined Multiple I/O) Interface</b>	<ul style="list-style-type: none"> <li>• 1x High Speed CMI Interface for optional CMI Module Expansion</li> <li>• 1x Low Speed CMI Interface for optional CMI Module Expansion</li> </ul>
<b>CFM (Control Function Module) Interface</b>	<ul style="list-style-type: none"> <li>• 1x CFM IGN Interface for optional CFM-IGN Module Expansion</li> </ul>
<b>Other Function</b>	
<b>External FAN Connector</b>	<ul style="list-style-type: none"> <li>• 1x External FAN Connector, 4-pin Terminal Block (Support Smart Fan by BIOS)</li> </ul>
<b>Power Ignition Sensing</b>	<ul style="list-style-type: none"> <li>• Support Power Ignition Sensing Function with Delay Time Management and Selectable 12V/24V (With Optional CFM Module)</li> </ul>
<b>Clear CMOS Switch</b>	<ul style="list-style-type: none"> <li>• 1x Clear CMOS Switch</li> </ul>
<b>Reset Button</b>	<ul style="list-style-type: none"> <li>• 1x Reset Button</li> </ul>
<b>Instant Reboot</b>	<ul style="list-style-type: none"> <li>• Support 0.2sec Instant Reboot Technology</li> </ul>
<b>Watchdog Timer</b>	<ul style="list-style-type: none"> <li>• Software Programmable Supports 256 Levels System Reset</li> </ul>
<b>Power</b>	
<b>Power Button</b>	<ul style="list-style-type: none"> <li>• 1x ATX Power On/Off Button</li> </ul>
<b>Power Mode Switch</b>	<ul style="list-style-type: none"> <li>• 1x AT/ATX Mode Switch</li> </ul>
<b>Power Input</b>	<ul style="list-style-type: none"> <li>• 9 - 48VDC, 3-pin Terminal Block</li> </ul>
<b>Remote Power On/Off</b>	<ul style="list-style-type: none"> <li>• 1x Remote Power On/Off, 2-pin Terminal Block</li> </ul>
<b>Remote Power LED</b>	<ul style="list-style-type: none"> <li>• 1x Remote Power LED, 2-pin Terminal Block</li> </ul>
<b>Total Power Budget</b>	<ul style="list-style-type: none"> <li>• 120W</li> </ul>



<b>Physical</b>	
<b>Dimension (W x D x H)</b>	• 203 x 142 x 66.8 mm
<b>Weight Information</b>	• 1.74 KG
<b>Mechanical Construction</b>	• Extruded Aluminum with Heavy Duty Metal
<b>Mounting</b>	• Wall/ Side/ DIN-RAIL/ VESA Mount
<b>Physical Design</b>	<ul style="list-style-type: none"> <li>• Fanless Design</li> <li>• Cableless Design</li> <li>• Jumper-less Design</li> <li>• Unibody Design</li> </ul>
<b>Reliability &amp; Protection</b>	
<b>Reverse Power Input Protection</b>	• Yes
<b>Over Voltage Protection</b>	<ul style="list-style-type: none"> <li>• Protection Range: 51-58V</li> <li>• Protection Type: shut down operating voltage, re-power on at the present level to recover</li> </ul>
<b>Over Current Protection</b>	• 15A
<b>Surge Protection</b>	• 2 kV
<b>CMOS Battery Backup</b>	• SuperCap Integrated for CMOS Battery Maintenance-free Operation
<b>MTBF</b>	<ul style="list-style-type: none"> <li>• MTBF: 513,628 hours</li> <li>- Database: Telcordia SR-332 Issue3, Method 1, Case 3</li> </ul>
<b>Operating System</b>	
<b>Windows</b>	• Windows® 10
<b>Linux</b>	• Supports by project
<b>Environment</b>	
<b>Operating Temperature</b>	<ul style="list-style-type: none"> <li>• 15W CPU: -40°C to 70°C</li> <li>* PassMark Burn-In Test: 100% CPU, 2D/3D Graphics (without thermal throttling)</li> <li>* With extended temperature peripherals; Ambient with air flow</li> <li>* According to IEC60068-2-1, IEC60068-2-2, IEC60068-2-14</li> <li>• 15W CPU + 61.6W PoE + FAN: -40°C to 70°C</li> <li>* PassMark Burn-In Test: 100% CPU, 2D/3D Graphics (without thermal throttling)</li> <li>* 4 Port PoE Full-load, IEEE 802.3af Class3(15.4 Watt)</li> <li>* With extended temperature peripherals; Ambient with air flow</li> </ul>
<b>Storage Temperature</b>	• -40°C to 85°C

<b>Relative Humidity</b>	• 95%RH @ 70°C (non-Condensing)
<b>Shock</b>	• MIL-STD-810G
<b>Vibration</b>	• MIL-STD-810G
<b>EMC</b>	• CE, FCC, ICES-003 Class A, EN50121-3-2 (Railway), E-mark
<b>Safety</b>	• IEC/EN 62368-1

*\* Product Specifications and features are for reference only and are subject to change without prior notice. For more information, please refer to the latest product datasheet from Cincoze's website.*

# 1.6 System I/O

## 1.6.1 Front

### ATX Power On/Off

Used to power-on or power-off the system

### Power LED

Indicates the power status of the system

### HDD LED

Indicates the status of the hard drive

### HDMI

Used to connect the system with HDMI monitor

### USB 2.0

Used to connect USB 2.0 device

### USB 3.2 Gen2

Used to connect USB 3.2 Gen2/3.2 Gen1/2.0 device

### Universal I/O Bracket

Used for customized I/O output

### Removable 2.5" HDD Tray

Used to inserts a 2.5" HDD

### SIM1, SIM2

Each SIM socket used to insert a SIM card

### IGN Setting Switch

Used to set up IGN function

### AT/ATX

A switch used to select AT or ATX power mode

### Clear CMOS

A switch used to clear CMOS to reset BIOS

### Reset

A button used to reset the system

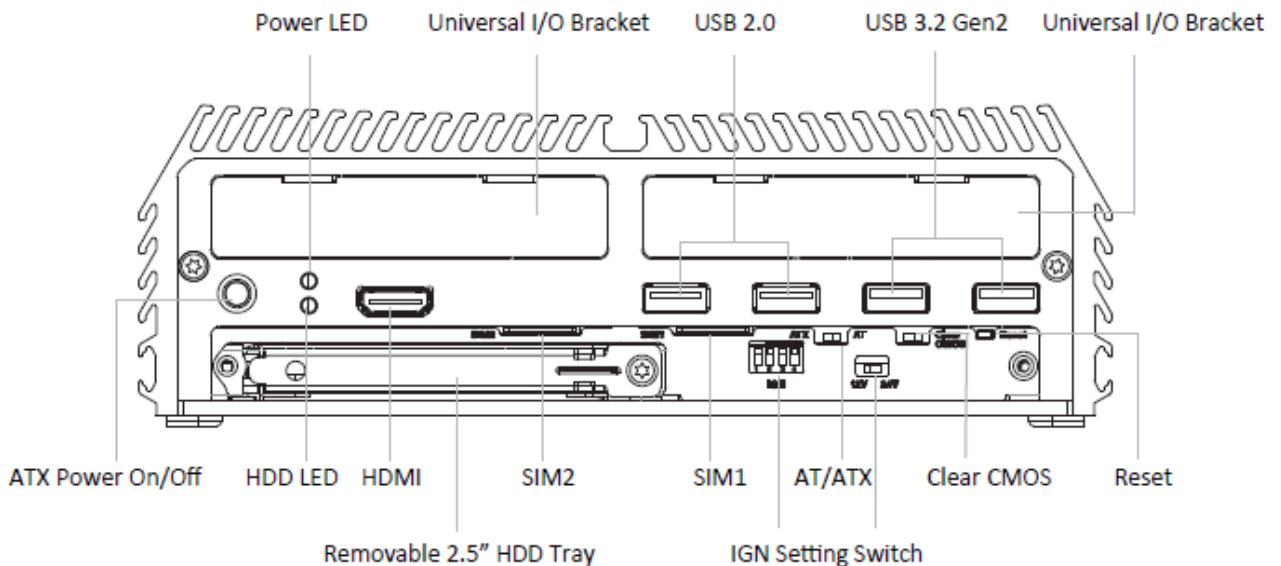

## 1.6.2 Rear

### Antenna

Used to connect an antenna for optional wireless module

### DC IN

Used to plug a DC power input with terminal block

### VGA

Used to connect a monitor with VGA interface

### FAN

External fan power used to plug an external fan with terminal block

### DP

Used to connect the system with DisplayPort monitor

### LAN1, LAN2

Used to connect to local area network

### PS/2

Used to connect the PS/2 device

### USB 3.2 Gen1

Used to connect USB 3.2 Gen1/2.0 device

### COM1, COM2

Used to connect to RS-232/422/485 serial devices

### Mic-in

Used to connect a microphone

### Line-out

Used to connect a speaker

### Chassis GND

Used for shielding and grounding to prevent electrical shock.

### Remote Power LED

A terminal block used to connect to remote power on/off LED

### Remote Power On/Off

A terminal block used to connect to remote power on/off switch

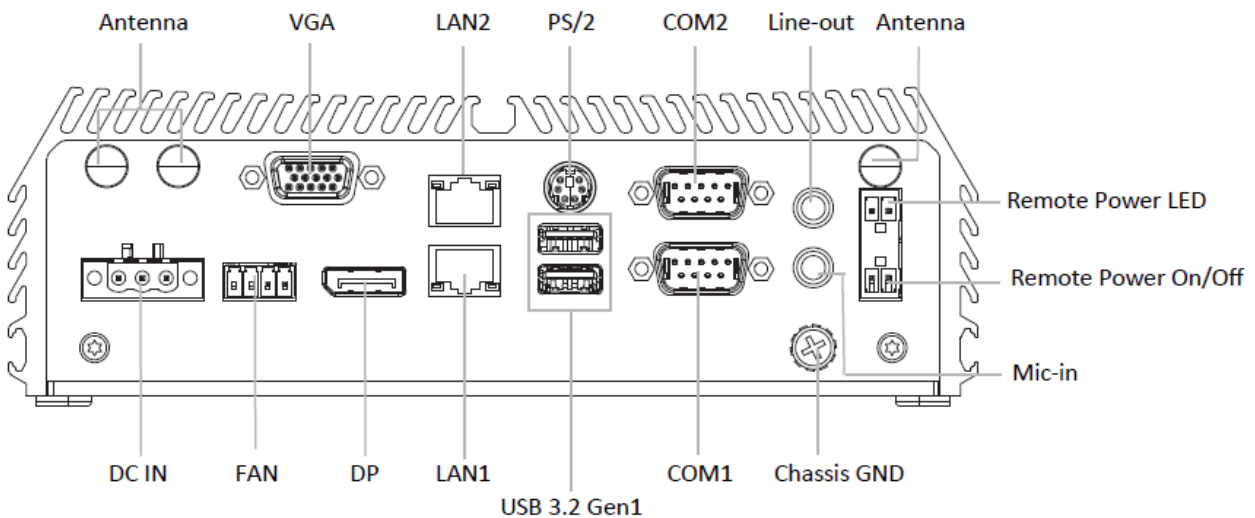

# 1.7 Mechanical Dimension

Unit: mm

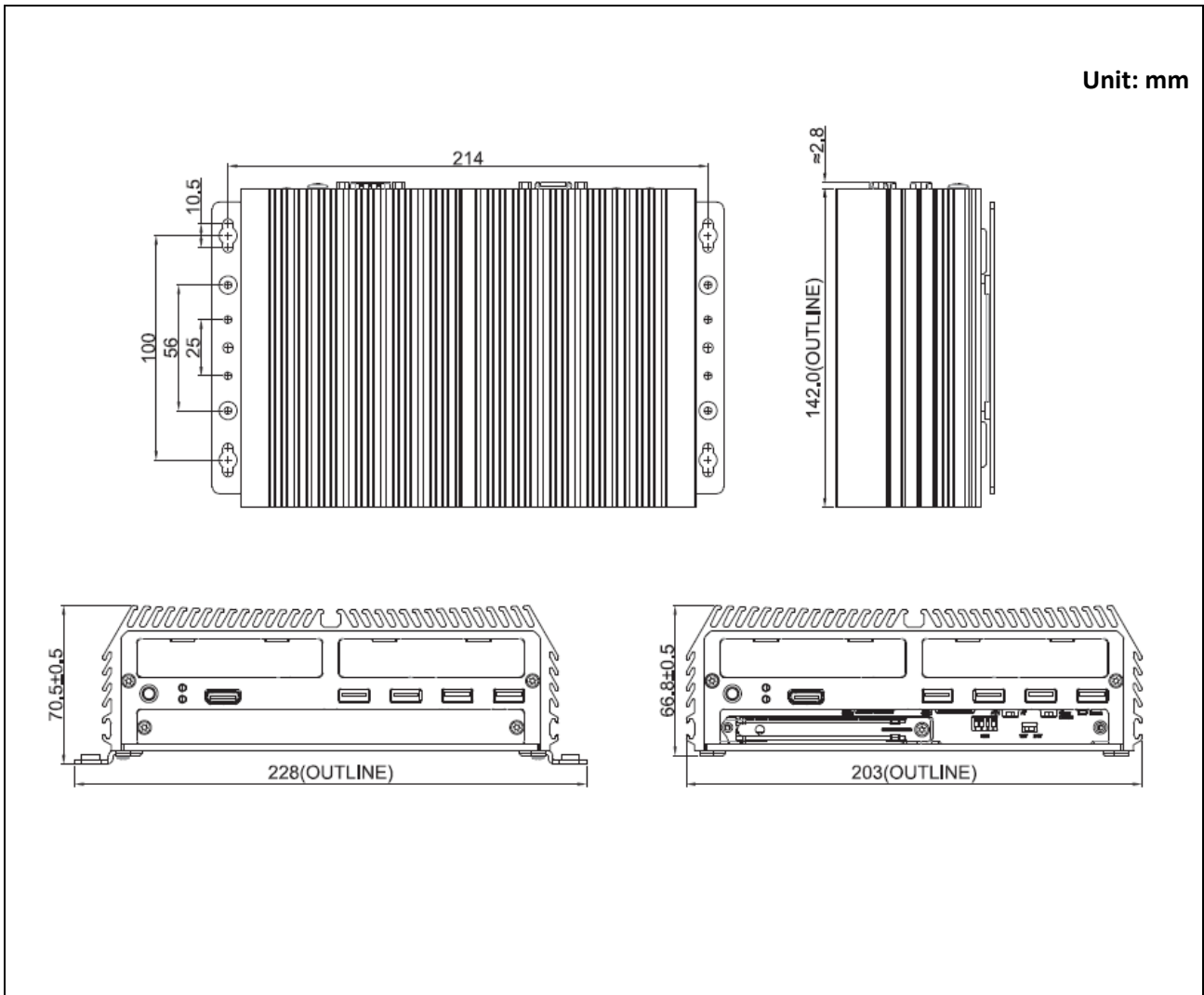



# **Chapter 2**

## **Switches & Connectors**

# 2.1 Location of Switches and Connectors

## 2.1.1 Top View

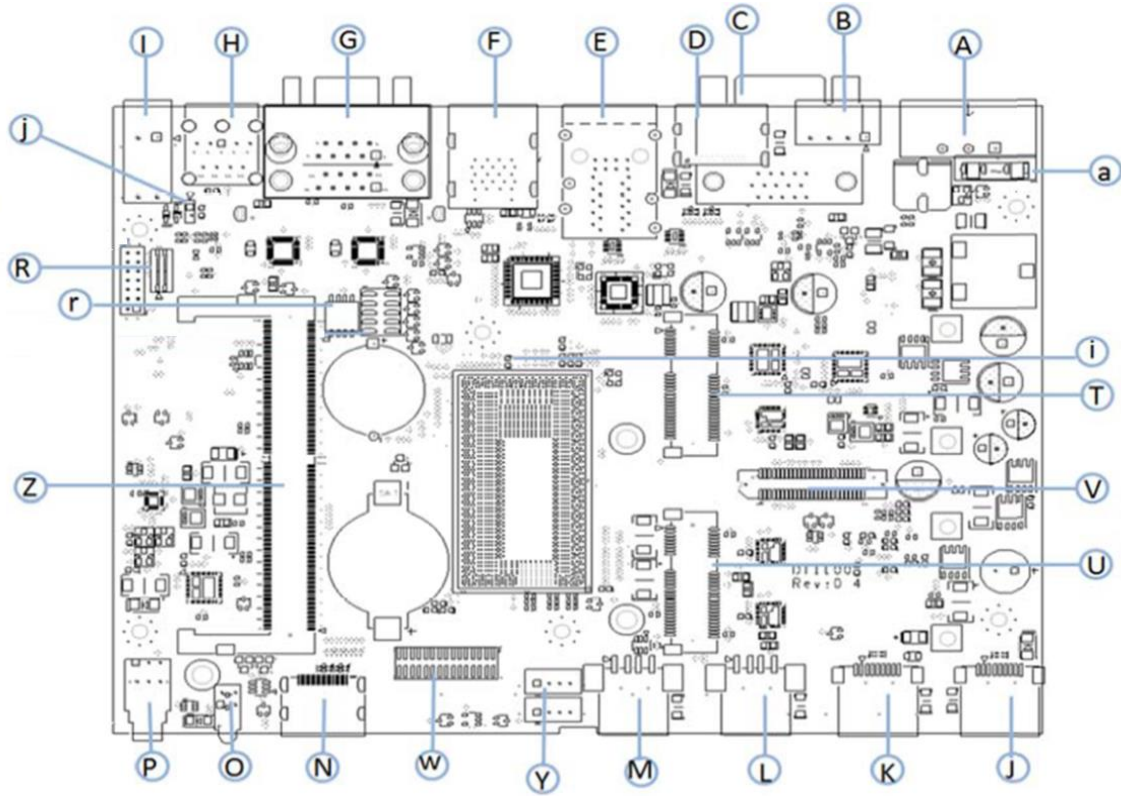

## 2.1.2 Bottom View

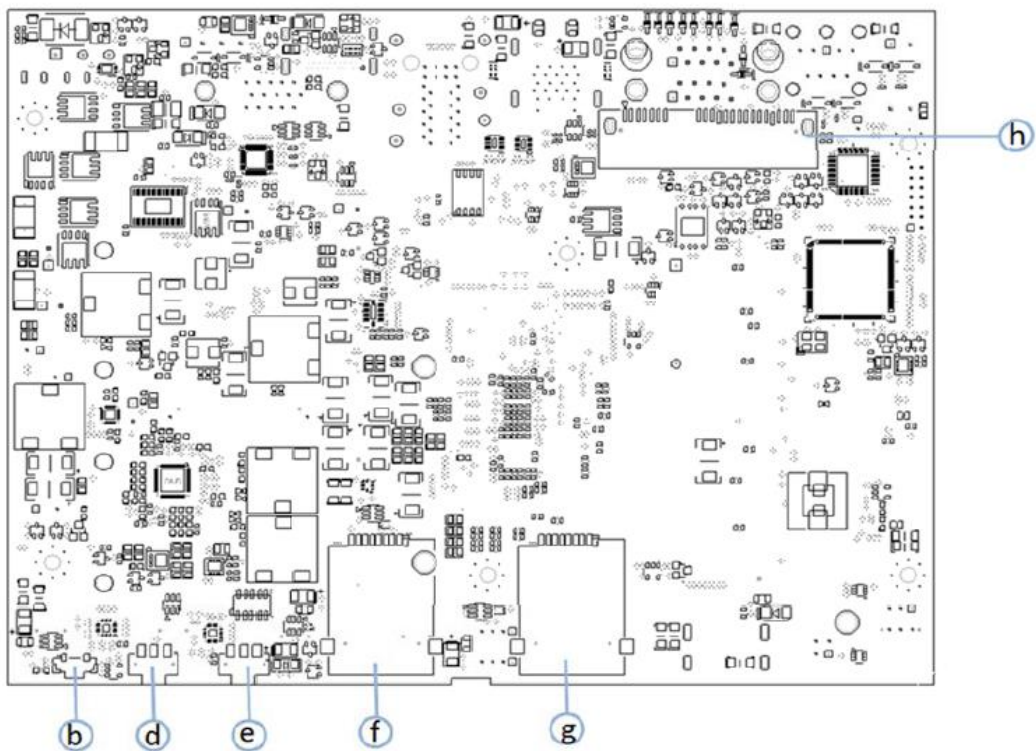

## 2.2 Switches and Connectors List

Location	Connector	Definition
A	DC_IN1	3 Pins DC 9-48V power input with power ignition connector
B	FAN1	CPU smart fan connector
C	VGA1	VGA connector (DB15)
D	DP1	Display port connector
E	CN2	Dual LAN RJ-45 connector
F	USB3_PS2_1	USB3.2 GEN1 X2 and PS2 connector
G	COM1/1	COM1 and COM2 connector
H	AUDIO1	Headphone and mic connector
I	CN1	Remote power on/off and power LED
J	USB3_2	USB3.2 GNE2 connector
K	USB3_1	USB3.2 GNE2 connector
L	USB2_1	USB2.0 connector
M	USB2_2	USB2.0 connector
N	JHDMI1	HDMI connector
O	LED1	Power and SATA LED
P	PWR_SW1	Power button
R	MODE_SEL1	Super CAP control switch
r	SW1	COM1 and COM2 power select
T	MINIPCIE1	PCIE Mini card connector, support PCIE/mSATA/USB3.0 socket
U	MINIPCIE2	PCIE Mini card connector, support PCIE/USB3.0 Dual SIM socket
V	BTB_FH1	CMI 50 pins slot, support PCIE 1X4 or 4x1 LAN/POE
W	BTB_FH2	CMI 30 pins slot, support 8 in 8 out DIO or COM3/4
Y	POWER1, POWER2	+5V/+12V power output connector
Z	DIMM1	DDR4 SO-DIMM connector
a	FS_1	DC input power 15A/58V
b	RESET1	Reset button
d	CLR_CMOS1	Clear COMS switch setting
e	AT_ATX1	AT_ATX1 switch setting
f, g	SIM1, SIM2	SIM Card socket A and B
h	SATA2	22 Pins SATA connector



## 2.3 Definition of Switches and Connectors

### AT\_ATX1: AT/ ATX Power Mode Switch

Switch	Definition
Left	ATX Power Mode (Default)
Right	AT Power Mode



### CLR\_CMOS1: Clear BIOS Switch

Switch	Definition
Left	Normal Status (Default)
Right	Clear BIOS



### RESET1: Reset Button

Switch	Definition
Push	Reset System

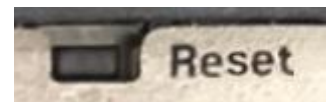

### LED1: Power/ HDD Access LED Status

LED1	LED Color
POWER	Green
HDD	Yellow



### PWR\_SW1: Power button

Switch	Definition
Push	Power System



### MODE\_SEL1: Super CAP Function Setting

Location	Function	DIP1	DIP2
MODE_SEL1	Super CAP Enabled	ON (Default)	ON (Default)
	Super CAP Disabled	OFF	

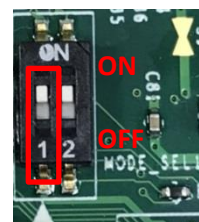

**SW1: COM1/ COM2 Power Select**

Location	Function		DIP1	DIP2
SW1	COM1	0V(RI)	ON (Default)	ON (Default)
		5V	ON	OFF
		12V	OFF	OFF
Location	Function		DIP3	DIP4
SW1	COM2	0V(RI)	ON (Default)	ON (Default)
		5V	ON	OFF
		12V	OFF	OFF

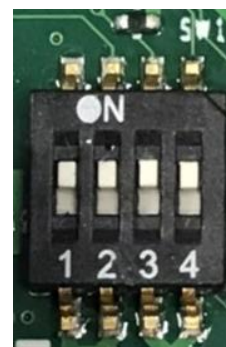

**LAN LED Status Definition**

Link LED Status	Definition
Steady Green	1 Gbps Network Link
Steady Orange	100 Mbps Network Link
Off	10 Mbps Network Link
Act LED Status	Definition
Blinking Yellow	Data Activity
Steady Yellow	No Activity

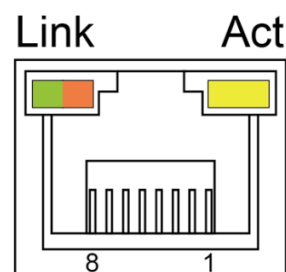

**MINIPCIE1: Mini PCI-Express Socket (Support mPCIe/ mSATA/ USB3.0)**

Pin	Definition	Pin	Definition	Pin	Definition
1	WAKE#	19	NA	37	RESERVED
2	3.3V	20	3.3V	38	USB_D+
3	NA	21	GND	39	3.3V
4	GND	22	PERST#	40	GND
5	NA	23	PERN0/SATARPO	41	3.3V
6	1.5V	24	3.3V	42	NA
7	CLKREQ#	25	PERPO/SATARN0	43	GND
8	RESERVED	26	GND	44	NA
9	GND	27	GND	45	NA
10	NA	28	+1.5V	46	NA
11	REFCLK-	29	GND	47	NA
12	NA	30	SMB_CLK	48	+1.5V
13	REFCLK+	31	PETN0/SATATN0	49	NA
14	NA	32	SMB_DATA	50	GND
15	GND	33	PETPO/SATATPO	51	NA
16	NA	34	GND	52	+3.3V
17	NA	35	GND		
18	GND	36	USB_D-		

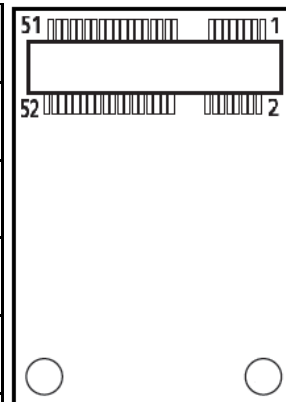

**MINIPCIE2: Mini PCI-Express Socket (Support mPCIE/ USB3.0/ SIM module)**

Pin	Definition	Pin	Definition	Pin	Definition
1	WAKE#	19	NA	37	GND
2	3.3V	20	3.3V	38	USB_D+
3	NA	21	GND	39	3.3V
4	GND	22	PERST#	40	GND
5	NA	23	PERN1/SATARP1	41	3.3V
6	1.5V	24	3.3V	42	NA
7	CLKREQ#	25	PERP1/SATARN1	43	GND
8	SIM_PWR	26	GND	44	NA
9	GND	27	GND	45	NA
10	SIM_DATA	28	+1.5V	46	NA
11	REFCLK-	29	GND	47	NA
12	SIM_CLK	30	SMB_CLK	48	+1.5V
13	REFCLK+	31	PETN1/SATATN1	49	NA
14	SIM_RESET	32	SMB_DATA	50	GND
15	GND	33	PETP1/SATATP1	51	NA
16	SIM_VPP	34	GND	52	+3.3V
17	NA	35	GND		
18	GND	36	USB_D-		

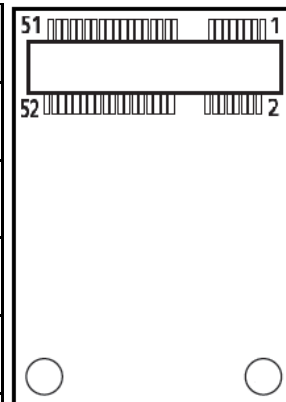

### COM1/ COM2 : RS232/ RS422/ RS485 Connector

Connector Type: 9-pin D-Sub

Pin	RS232 Definition	RS422/ RS485 Full Duplex Definition	RS485 Half Duplex Definition
1	DCD	TX-	DATA -
2	RXD	TX+	DATA +
3	TXD	RX+	
4	DTR	RX-	
5	GND		
6	DSR		
7	RTS		
8	CTS		
9	RI		



### POWER1/ POWER2: +5V/ +12V Power Output Connector

Connector Type: 1X4-pin Wafer, 2.0 mm pitch

Pin	Definition
1	+5V
2	GND
3	GND
4	+12V

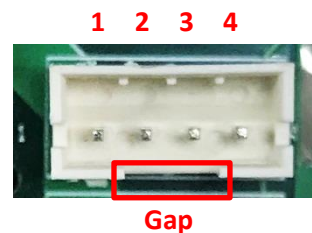

### CN1 : Remote power button/ LED Connector

Remote Power LED connector can connect an external LED indicator up to 10mA. Connector Type: Terminal Block 2X2 4-pin, 3.5mm pitch

Pin	Definition
1	PWR_SW
2	RMT_PWR_LED_A
3	GND
4	GND

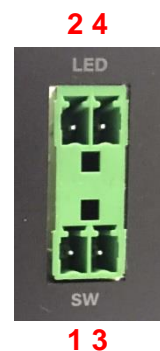

**WARNING**

**Do not apply power to this connector!**

### FAN1: CPU Smart Fan Connector

Connector Type: Terminal Block 1X4 4-pin, 3.5mm pitch

Pin	Definition
1	GND
2	+12V
3	FAN_IN
4	FAN_PWM

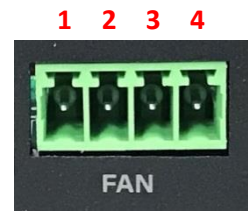

### DC\_IN1: 3 PINS DC 9-48V power input with power ignition connector

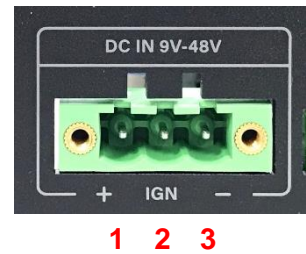

Connector Type: Terminal Block 1x3 3-pin, 5.0mm pitch

Pin	Definition
1	+9-48VIN
2	Ignition (IGN)
3	GND



**CAUTION**

**Please disconnect the power source before mounting the DC power cables or connecting the DC power connector to system.**



# **Chapter 3**

## **System Setup**

## 3.1 Removing Top Cover



### WARNING

In order to prevent electric shock or system damage, before removing the chassis cover, must turn off power and disconnect the unit from power source.

1. Turn over the unit to have the bottom side face up, loosen the 6 screws on the bottom cover and place them aside for later use.

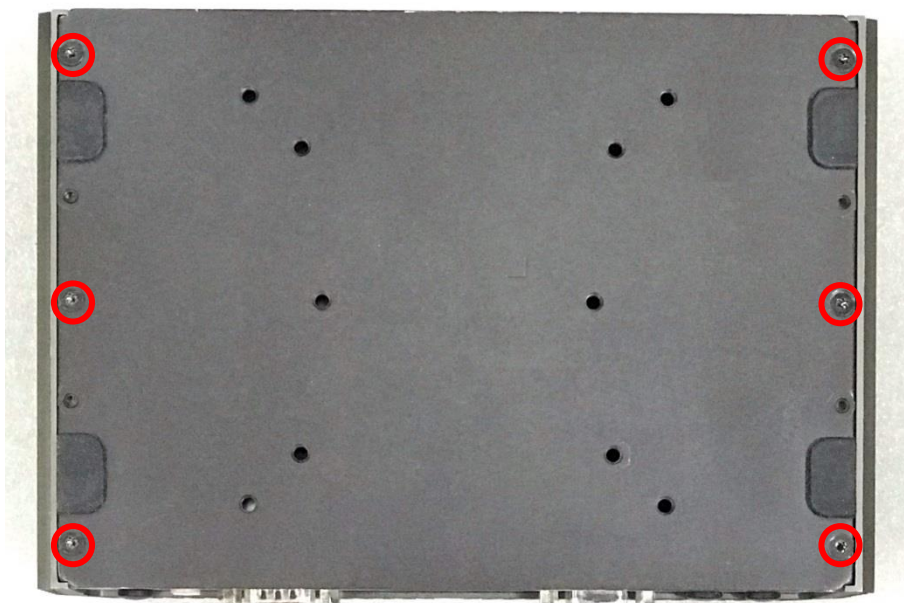

2. Remove the bottom cover from the chassis.





3. Lift up the unit vertically by holding the front and rear panel.

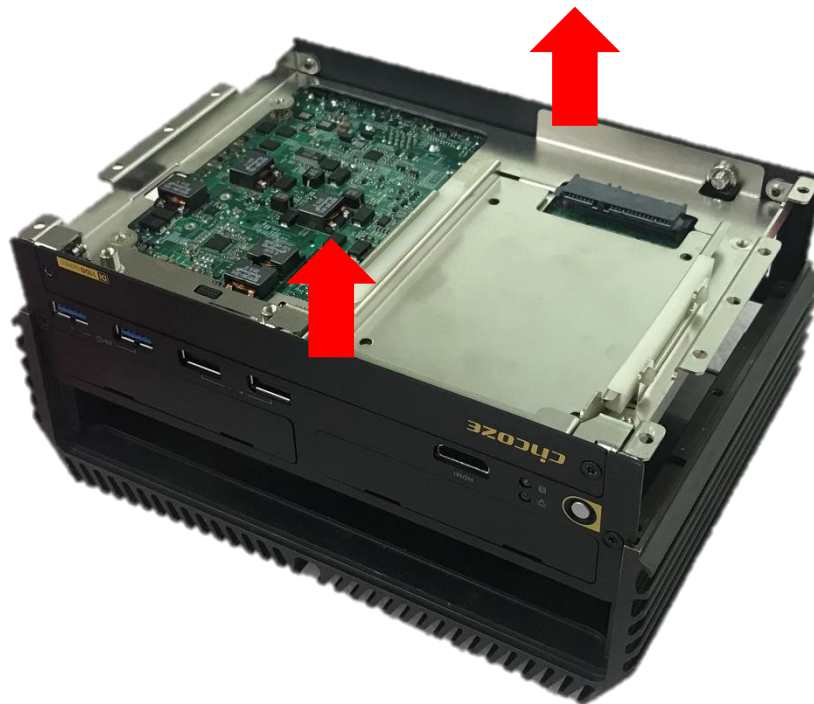

4. Turn over the body of the unit and place it gently.



## 3.2 Installing SO-DIMM

1. Locate the SO-DIMM socket on the top side of system.

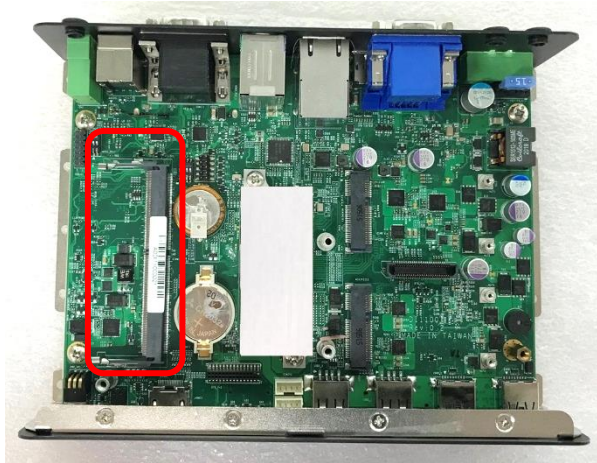

2. Insert the SO-DIMM at a 45-degree angle until its edge connector is connected to the SO-DIMM socket firmly.



3. Press down the module until the retaining clips snap back in place.



### 3.3 Installing Mini-PCIe Card

1. Locate the Mini PCIe socket on the top side of the system.

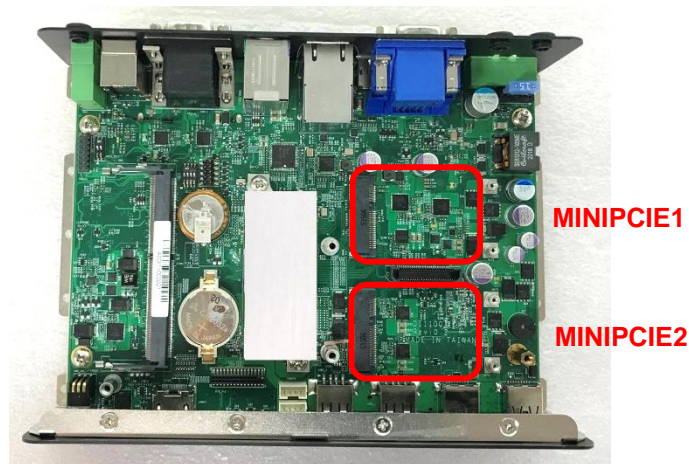

2. Use provided two screws fasten the half size module and adapter bracket together as shown in Fig (a) below.



(a) Half Size Mini-PCIe

(b) Full Size Mini-PCIe Card

3. Tilt a Mini PCIe card at a 45-degree angle and insert it to the socket until the golden finger connector of the card seated firmly.

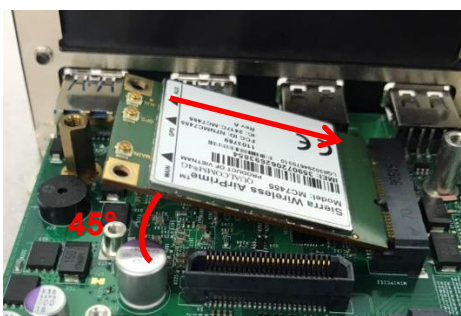

4. Press the card down and secure it with 2 screws.

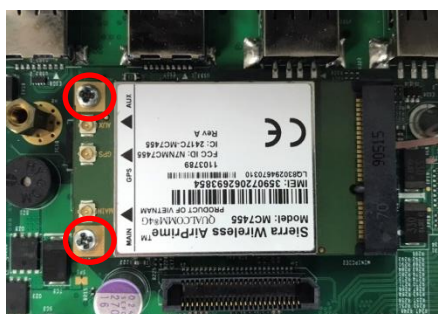

## 3.4 Installing Antenna



**NOTE**

Please install a Mini PCIe wireless LAN card at MINIPCI-E socket before antenna installation.

1. Remove the antenna plug on the rear panel.



2. Penetrate the antenna jack through the hole.

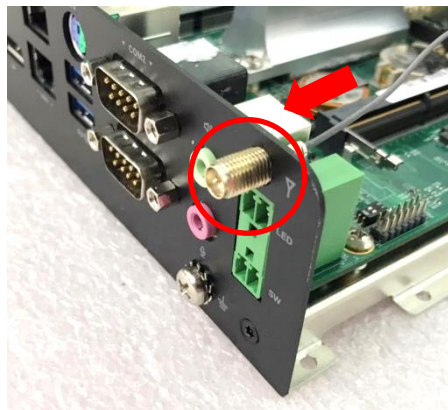

3. Put on the washer and fasten the nut of antenna jack.

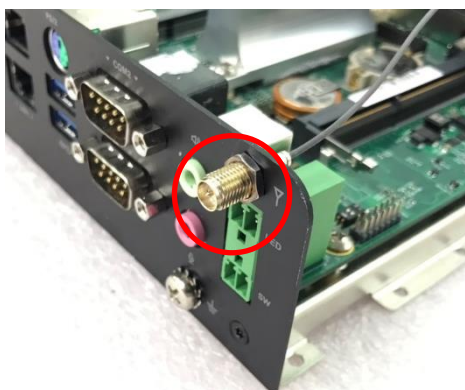

**CAUTION**

Installing an antenna jack with a diameter greater than 9 mm on the right side of the system will collide with the terminal connector below. In this case, please try to install the antenna on the left side of the system.

4. Assemble the antenna and antenna jack together.



5. Attach the RF connector of the cable's another end onto the card.



## 3.5 Installing the Thermal Pad

1. Please find the new thermal pad that is attached on the top cover of system.



2. Remove the protective film on the thermal pad.

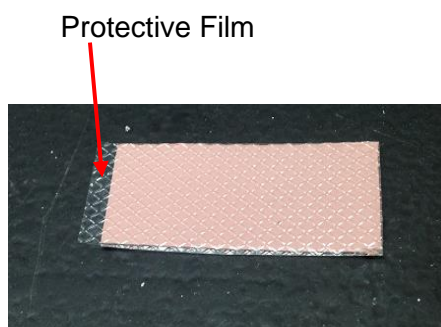

3. Paste the thermal pad onto the heatsink carefully.

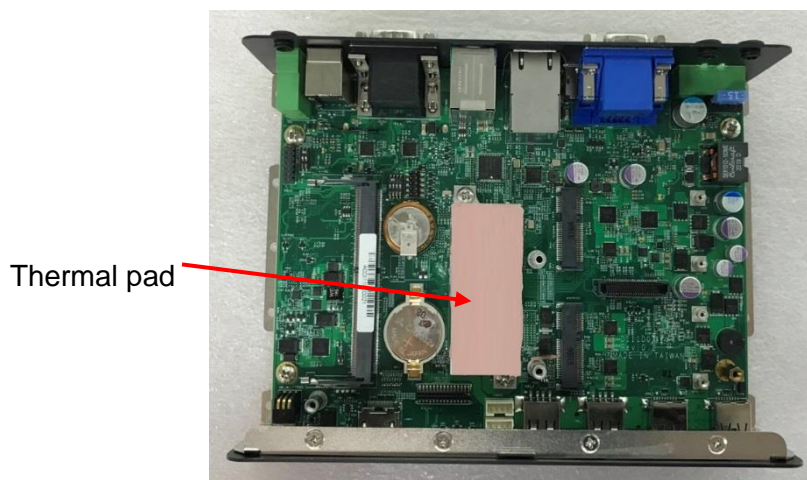

**CAUTION**

**Before assembling the system's chassis cover, please make sure the transparent protective film on the Thermal Pad has been removed!**

## 3.6 Assembling Top Cover

1. Make sure the notch on the chassis and the front bezel of the unit body are on the same side.



2. Lift the body of the unit, make sure that the front and rear panels are in the chassis grooves, and then assemble the body into the chassis.

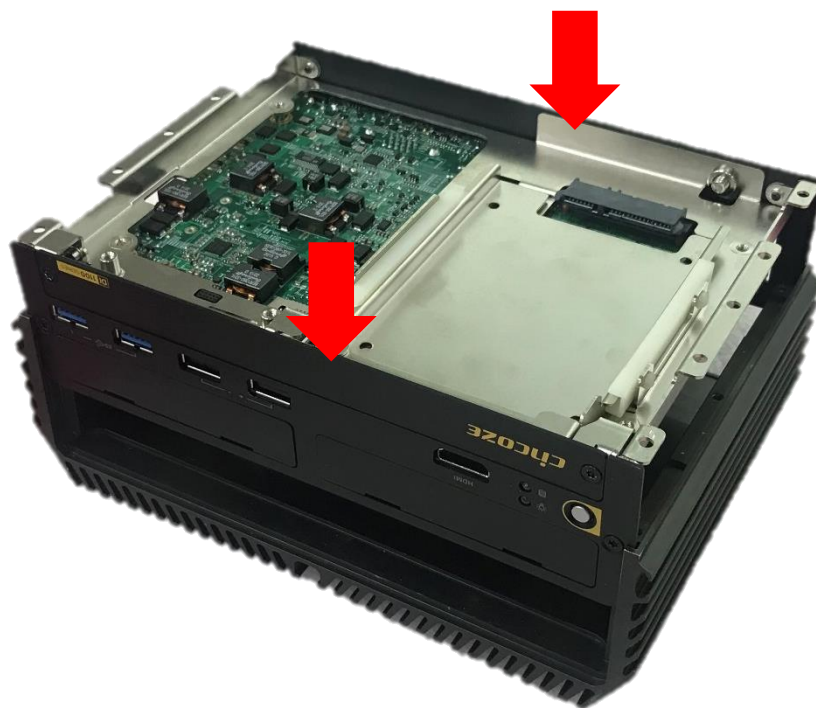

3. Place the bottom cover back to system.



4. Fasten the 6 screws to fix the cover.

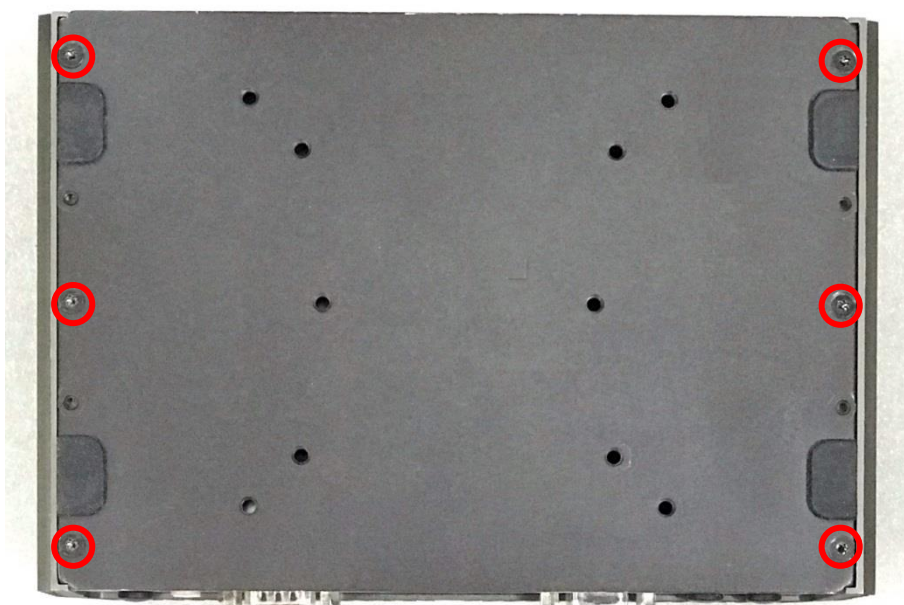



## 3.7 Installing SATA Hard Drives at Front Panel

1. Loosen the two screws to remove the cover plate of maintenance zone.



2. Loosen the screw to remove the HDD bay cover bracket.



3. Pull the rotating arm and pull the HDD bracket out of system.

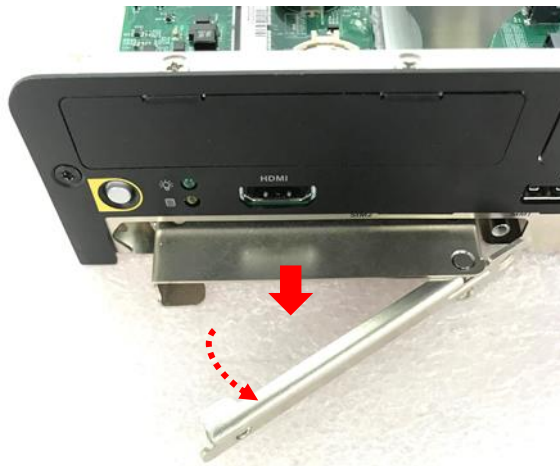

4. Make HDD bottom side face up, place the HDD bracket on it. Ensure the direction of bracket is correct and use 4 provided screws to assemble HDD and HDD bracket together.

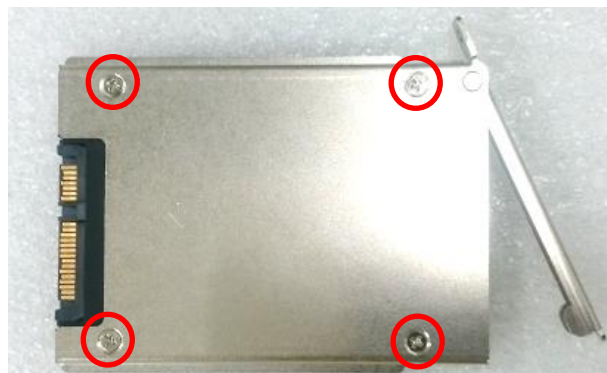

5. Align the HDD bracket with the entrance of HDD bay. Insert the HDD bracket and push it until the HDD connector is fully inserted into the SATA slot.

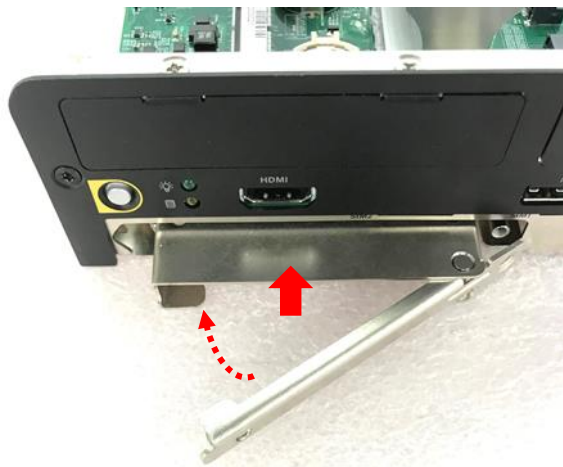

6. Place the rotating arm back and fasten the screw.



7. Fix the cover plate of maintenance zone by fastening the two screws.



## 3.8 Installing SIM Card

1. Loosen the two screws to remove the cover plate of maintenance zone.



2. Locate the SIM card slot at front side and insert a SIM card into a SIM slot with the gold contacts facing up. Please pay attention to the insert orientation as illustrated.

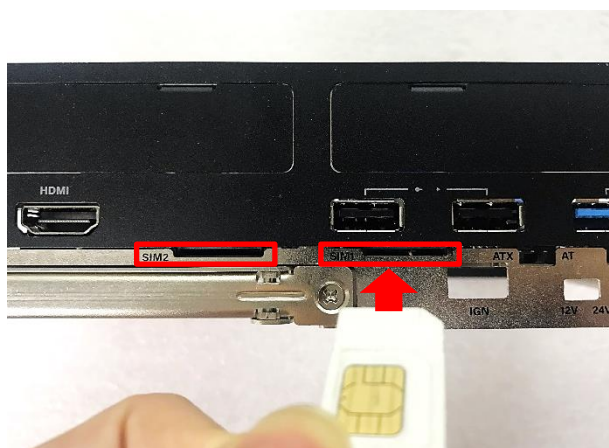

3. Fix the cover plate of maintenance zone by fastening the two screws.



## 3.9 Installing Wall Mount

DI-1100 series offers wall mount that customers can install system on the wall in a convenient and economical way.

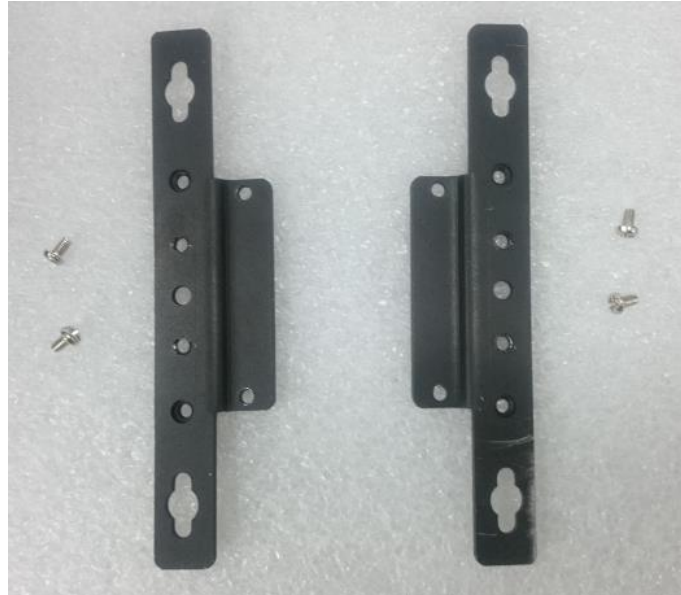

1. The mounting holes are at the bottom side of system. Use provided 4 screws to fasten the bracket on each side.



2. There are 2 bracket mounting holes at left and right side for customer fix the system on the wall.



## 3.10 VESA Mount

DI-1100 series supports VESA mounting that customer can mount system with panel complying with VESA 75mm and 100 mm standard for various usage.

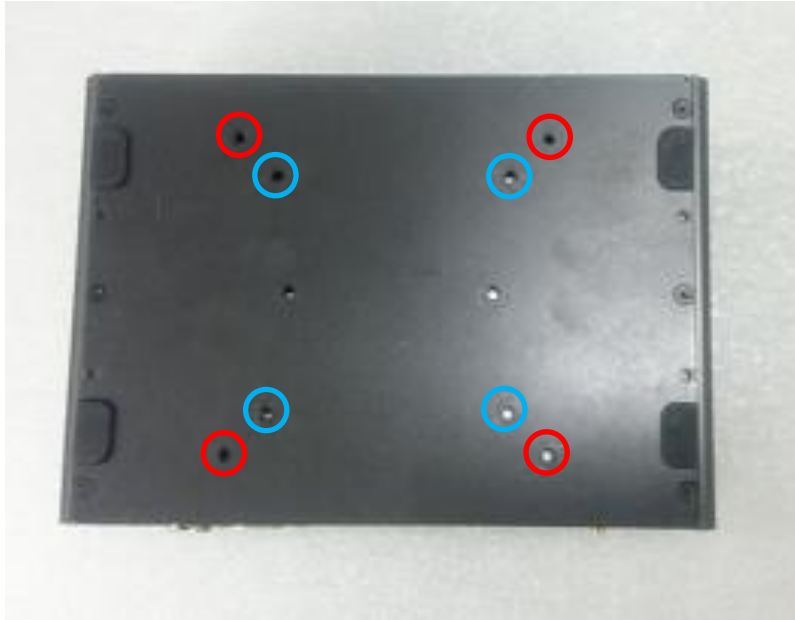

- 1 The following picture illustrates the installation of DI-1100 series on a VESA stand. Align the 4 screw holes of VESA stand with the screw holes on bottom side of system. Fasten 4 screws to fix it.

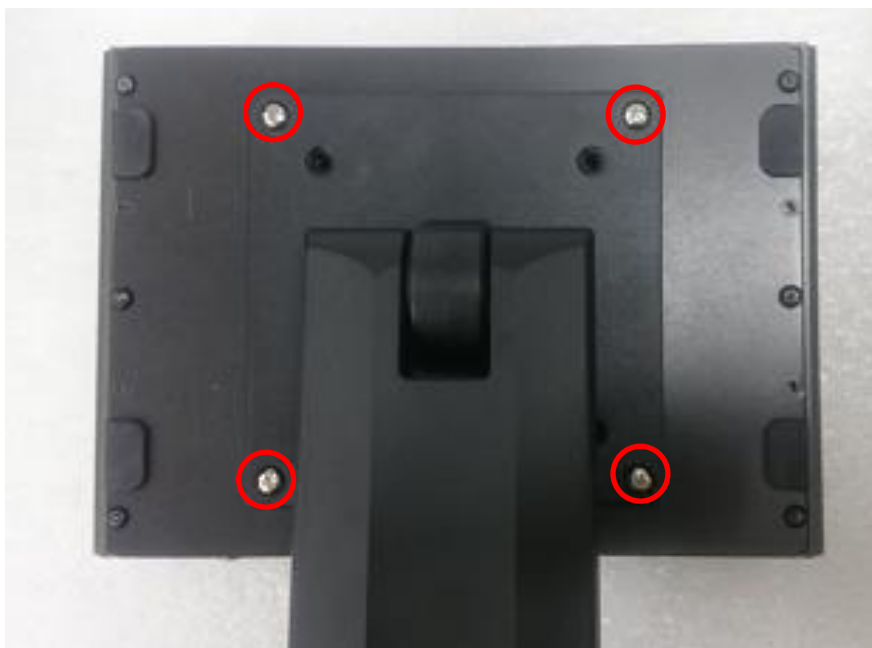

## 3.11 Connecting to Power Supply

1. Locate the DC\_IN1 power connector.



2. Aim the V- wire at the V- port of the connector, and aim the V+ wire at the V+ port of the connector. Then connect the phoenix contacts of the power supply to the DC\_IN1 connector.

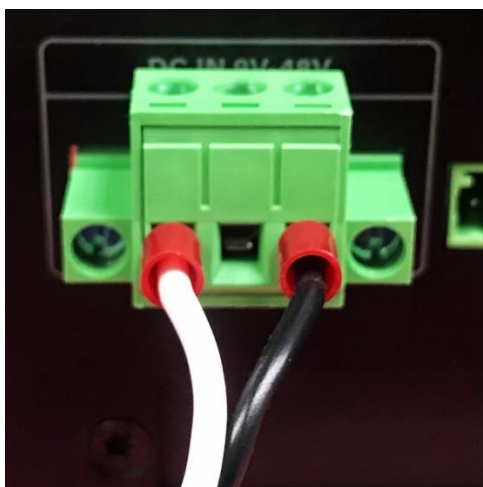

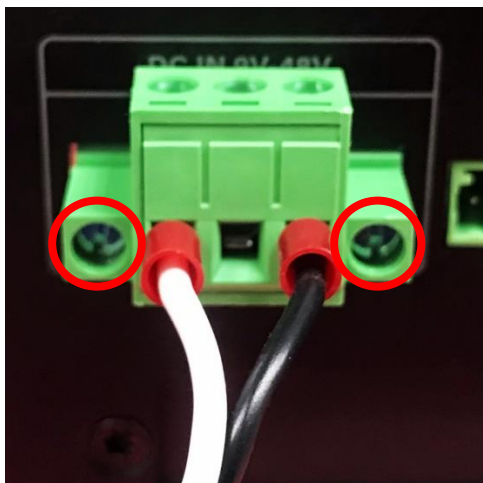

3. Fasten the two screws to fix the phoenix contacts.



**WARNING**

**In formal use, please use new Phoenix contacts and make sure the screws are tightened to avoid poor connection.**



# **Chapter 4**

## **BIOS Setup**



## 4.1 BIOS Introduction

The BIOS (Basic Input/ Output System) is a program located on a Flash Memory on the motherboard. When you start the computer, the BIOS program will gain control. The BIOS first operates an auto-diagnostic test called POST (power on self-test) for all the necessary hardware, it detects the entire hardware device and configures the parameters of the hardware synchronization.

### BIOS Setup

Power on the computer and by pressing <Del> immediately allows you to enter Setup. If the message disappears before your respond and you still wish to enter Setup, restart the system to try again by turning it OFF then ON or pressing <Ctrl>, <Alt> and <Delete> keys.

Control Keys	
<←> <→>	Move to select screen
<↑> <↓>	Move to select item
<Esc>	Quit the BIOS Setup
<Enter>	Select item
<Page Up/+>	Increases the numeric value or makes changes
<Page Down/->	Decreases the numeric value or makes changes
<Tab>	Select setup fields
<F1>	General help
<F2>	Previous value
<F3>	Load Optimized defaults
<F10>	Save configuration and Exit

### Main Menu

The main menu lists the setup functions you can make changes to. You can use the arrow keys ( ↑↓ ) to select the item. The on-line description of the highlighted setup function is displayed at the bottom of the screen.

### Sub-Menu

If you find a right pointer symbol appears to the left of certain fields that means a sub-menu can be launched from this field. A sub-menu contains additional options for a field parameter. You can use arrow keys ( ↑↓ ) to highlight the field and press <Enter> to call up the sub-menu. Then you can use the control keys to enter values and move from field to field within a sub-menu. If you want to return to the main menu, just press the <Esc >.

## 4.2 Main Setup

Press <Del> to enter BIOS CMOS Setup Utility, the Main Menu (as shown below) will appear on the screen. Use arrow keys to move among the items and press <Enter> to accept or enter a sub-menu.

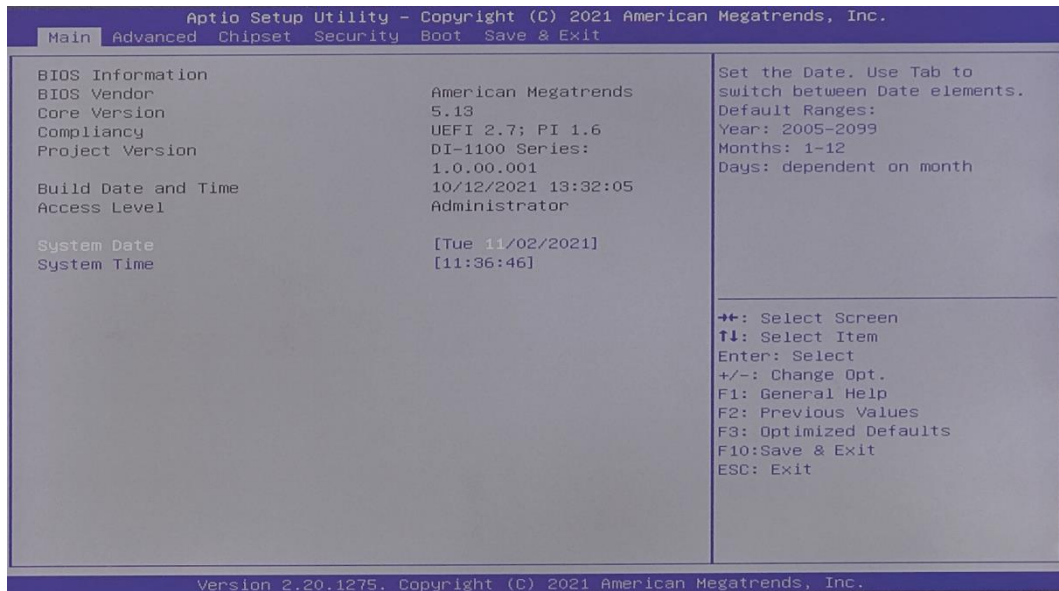

### 4.2.1 System Date

Set the date. Please use <Tab> to switch between date elements.

### 4.2.2 System Time

Set the time. Please use <Tab> to switch between time elements.

## 4.3 Advanced Setup

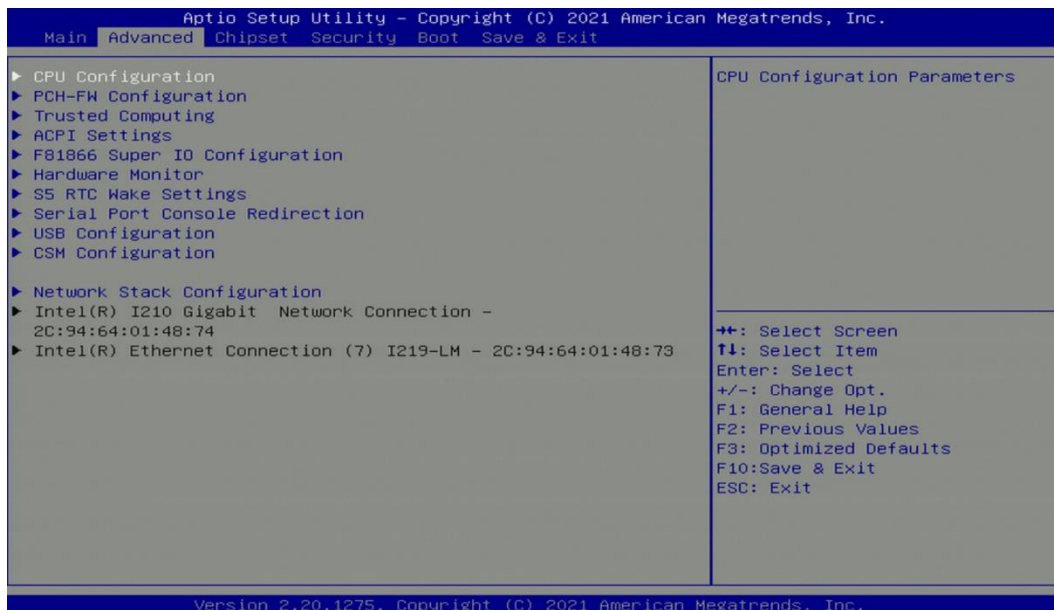

### 4.3.1 CPU Configuration

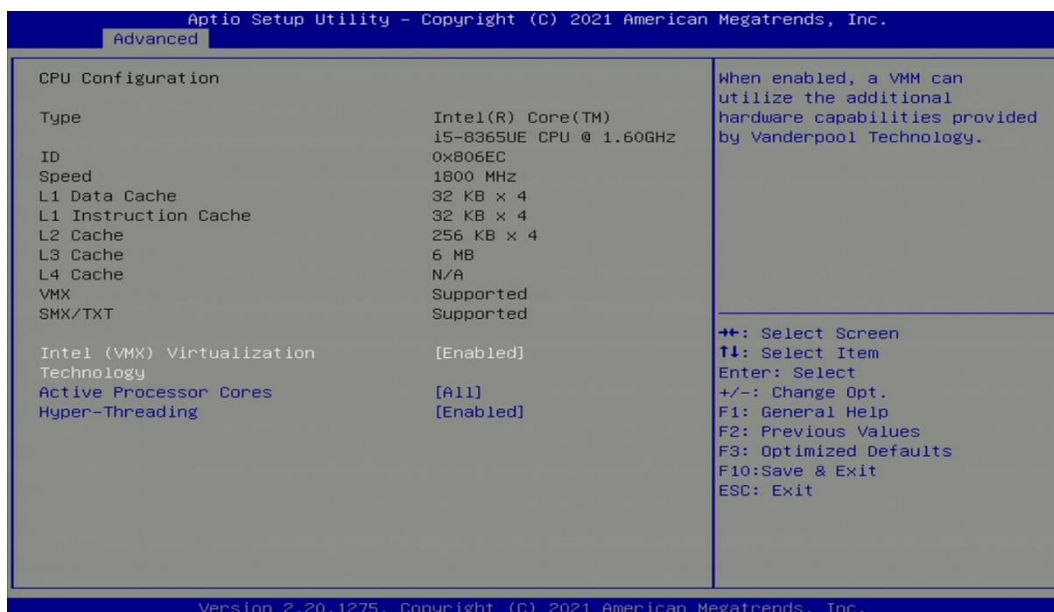

#### ■ Intel® (VMX) Virtualization Technology [Enabled]

Enables or disables Intel® Virtualization Technology. Virtualization enhanced by Intel® Virtualization Technology will allow a platform to run multiple operating systems and applications in independent partitions. With virtualization, one computer system can function as multiple virtual systems.

#### ■ Active Process Cores [All]

Allows users to choose the number of active processor cores.

Configuration options: [All] [1] [2] [3]

#### ■ Hyper-threading

Enables or disables for Hyper-Threading Technology.

### 4.3.2 PCH-FW Configuration

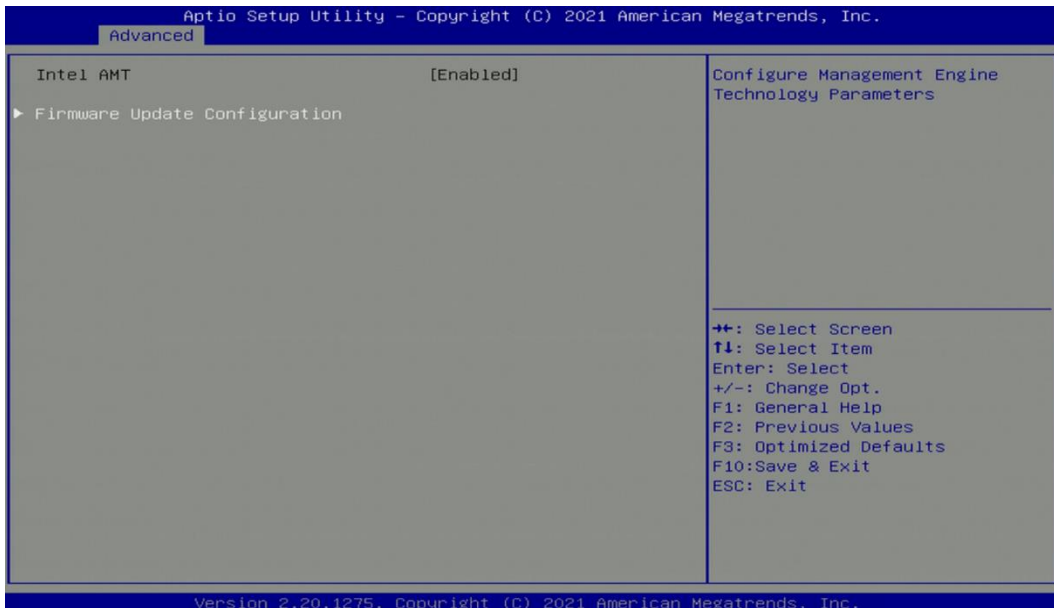

#### ■ Intel AMT [Enabled]

Allows users to enable or disable Intel® Active Management Technology BIOS execution. (This function can be opened for customization.)

#### ■ Firmware Update Configuration

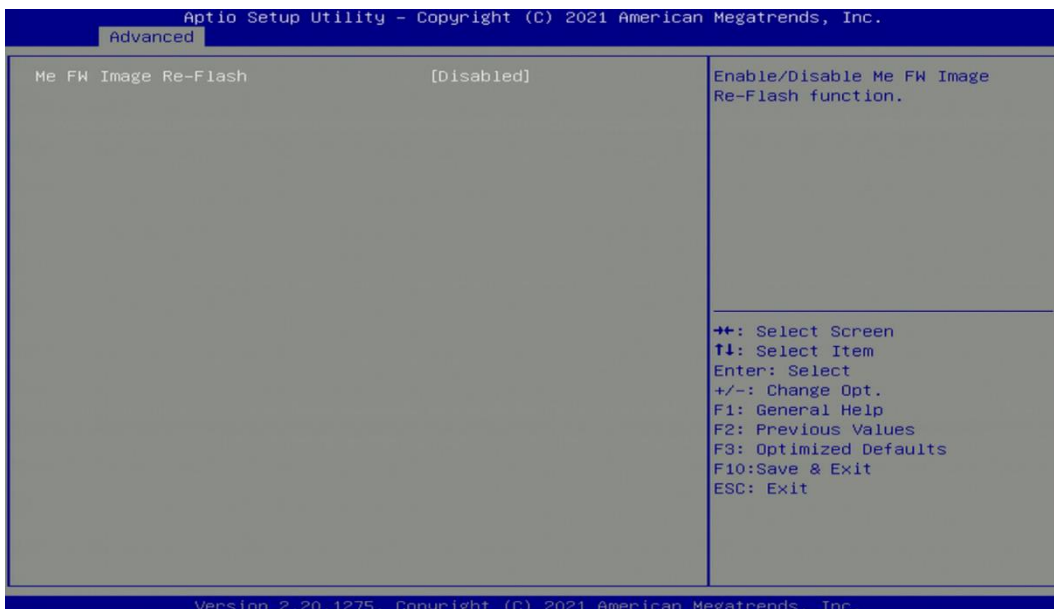

#### □ ME FW Image Re-Flash [Disabled]

Allows users to enable or disable ME firmware image re-flash function.

### 4.3.3 Trusted Computing

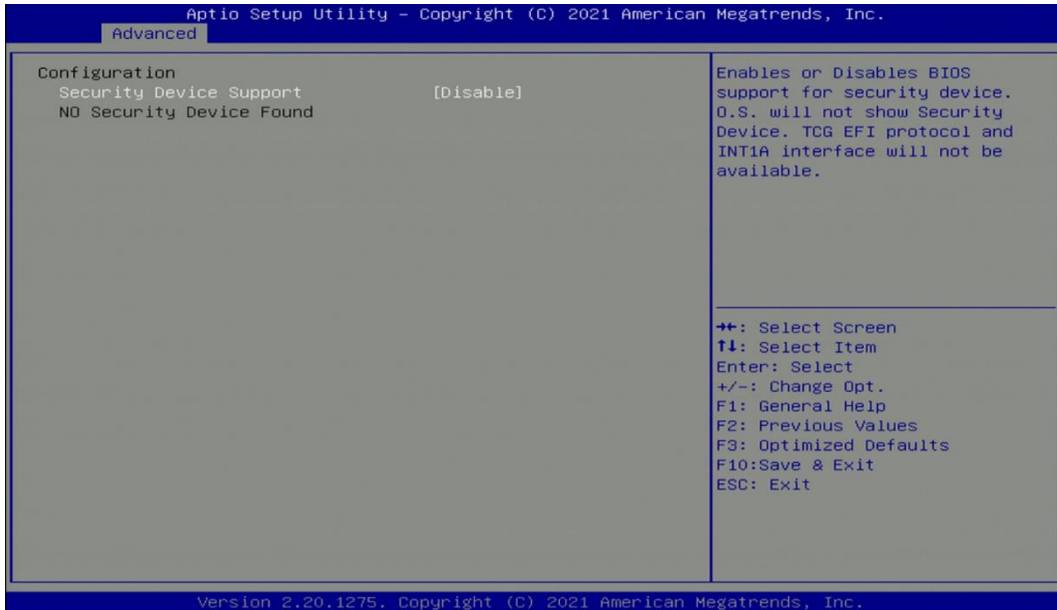

#### ■ Security Device Support [Disable]

Allow users to enable or disable Security Device Support function.

### 4.3.4 ACPI Settings

This item allows users to configure ACPI settings.

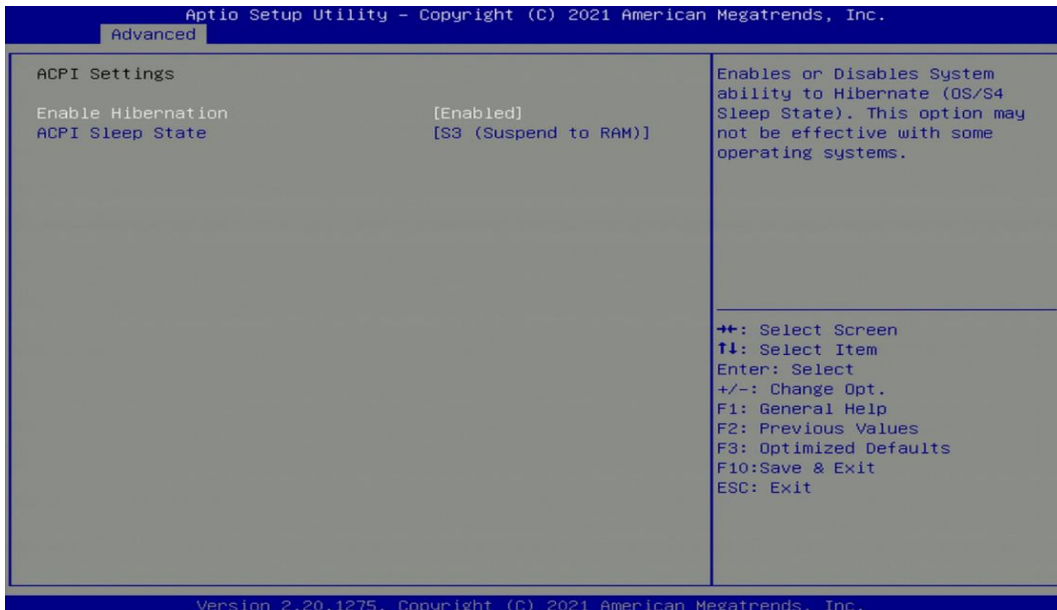

#### ■ Enable ACPI Auto Configuration [Enabled]

Enables or disables BIOS Advanced Configuration Power Interface® (ACPI) auto configuration.

#### ■ ACPI Sleep State [S3 (Suspend to RAM)]

Allows users to select the highest Advanced Configuration Power Interface® (ACPI) sleep state that system will enter when suspend button is pressed.

[Suspend Disabled]: Disables entering suspend state.

[S3 (suspend to RAM)]: Enables suspend to RAM state.

### 4.3.5 F81866 Super IO Configuration

The screen allows users to select options for the Super IO configuration, and change the value of the selected option.

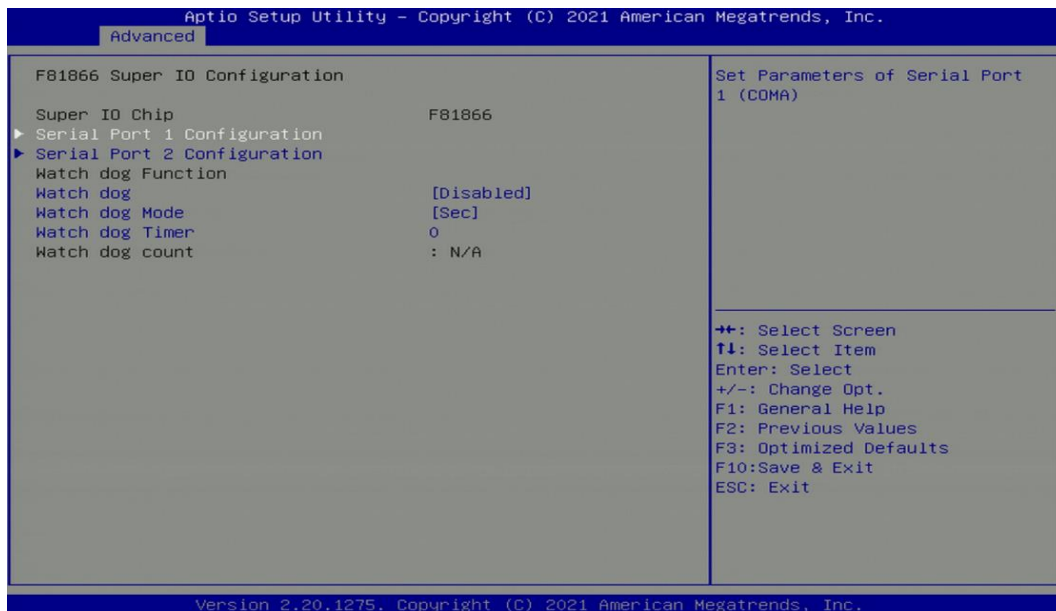

### Serial Port 1~2 Configuration

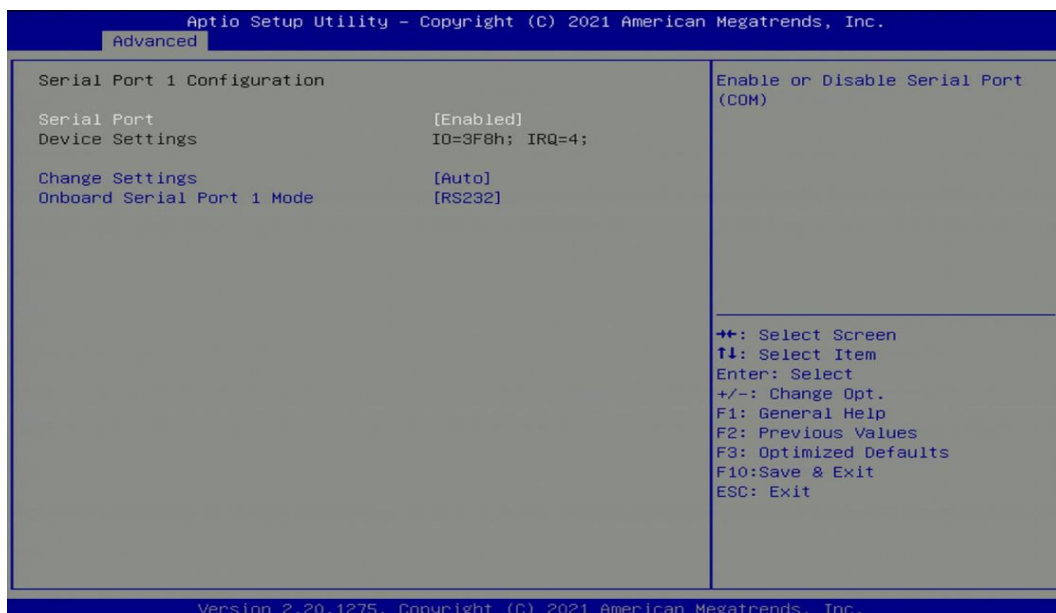

- Serial Port [Enabled]**  
This item allows users to enable or disable serial port.
- Change Settings [Auto]**  
This item allows users to change the address & IRQ settings of the specified serial port.
- Onboard Serial Port 1 Mode [RS232]**  
This item allows users to select Serial Port Mode.  
Configuration options: [RS232] [RS422/RS485 Full Duplex] [RS485 Half Duplex]

### ■ Watch Dog [Disabled]

Enables or disables watch dog function.

### ■ Watch Dog Mode [Sec]

Changes the Watch dog mode. Select [Sec] or [Min] mode.

### ■ Watch Dog Timer [0]

User can set a value in the range of 0 to 255.

## 4.3.6 Hardware Monitor

These items display the current status of all monitored hardware devices/ components such as voltages and temperatures.



### ■ External Smart Fan Function [Enabled]

Enables or disables external smart fan function.

### ■ External Smart Fan Configuration

Allows users to setting external smart fan parameters.

### 4.3.7 S5 RTC Wake Settings

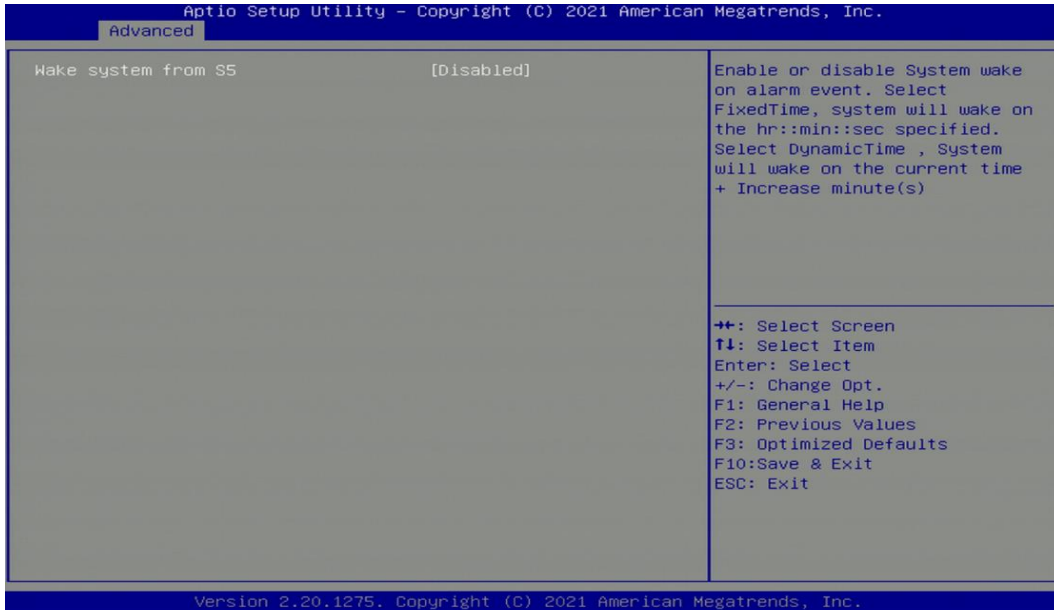

#### ■ Wake System from S5 [Disabled]

This item allows users to change the way to wake system from S5 state.

[Fixed Time]: Set the specified time (HH:MM:SS) to wake system.

[Dynamic Time]: Set the increase time from current time to wake system.

### 4.3.8 Serial Port Console Redirection

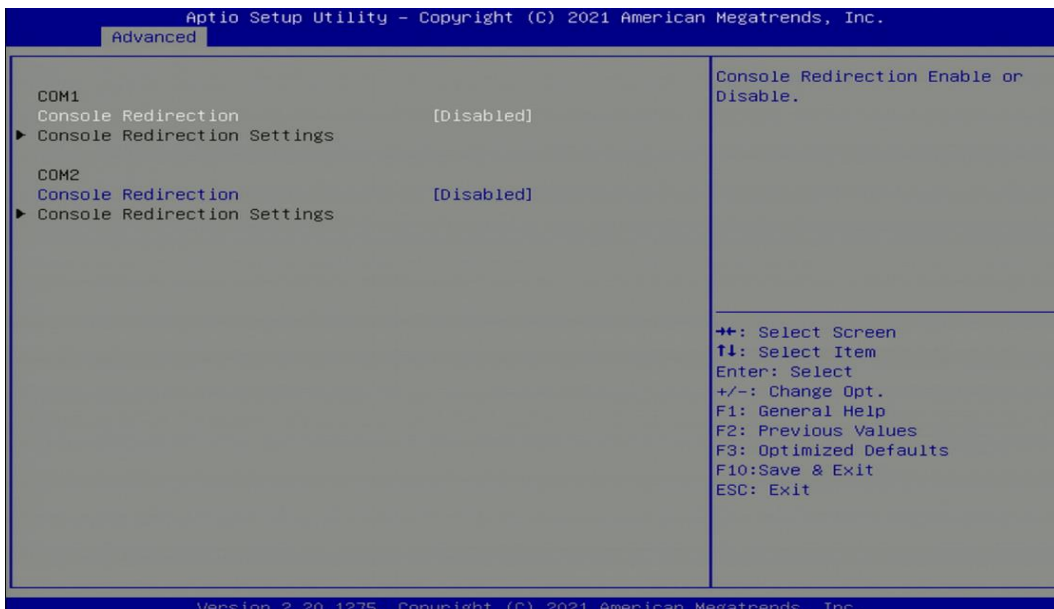

#### ■ Console Redirection [Disabled]

These items allow users to enable or disable COM1, COM2 console redirection function.



### 4.3.9 USB Configuration

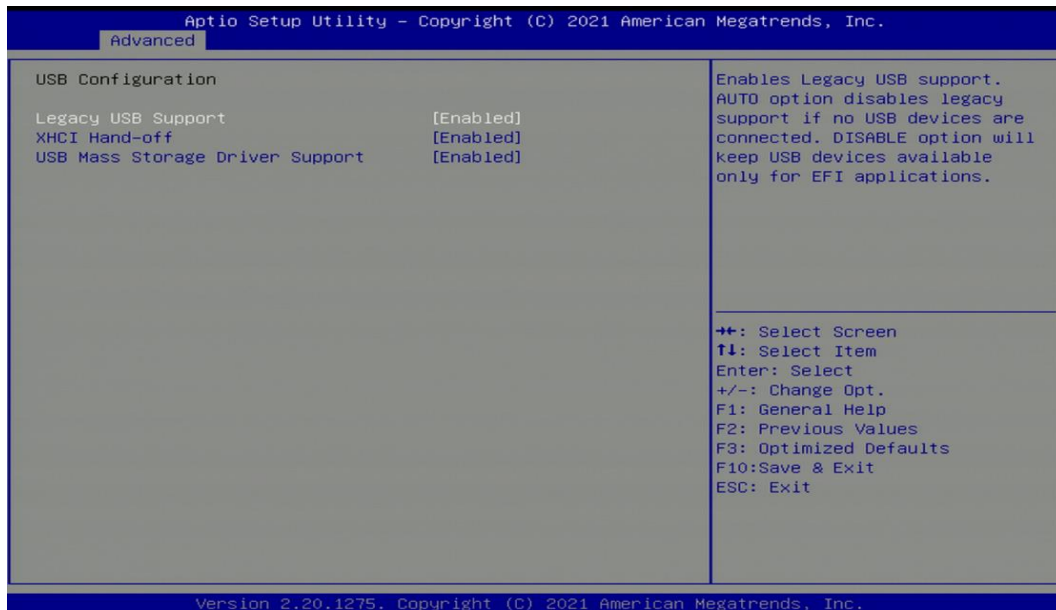

#### ■ Legacy USB Support [Enabled]

This item allows users to enable or disable legacy USB support. When set to [Auto], legacy USB support will be disabled automatically if no USB devices are connected.

#### ■ XHCI Hand-off [Enabled]

This item allows users to enable or disable XHCI (USB3.2) hand-off function.

#### ■ USB Mass Storage Driver Support [Enabled]

Enables or disables support for USB mass storage devices.

### 4.3.10 CSM Configuration

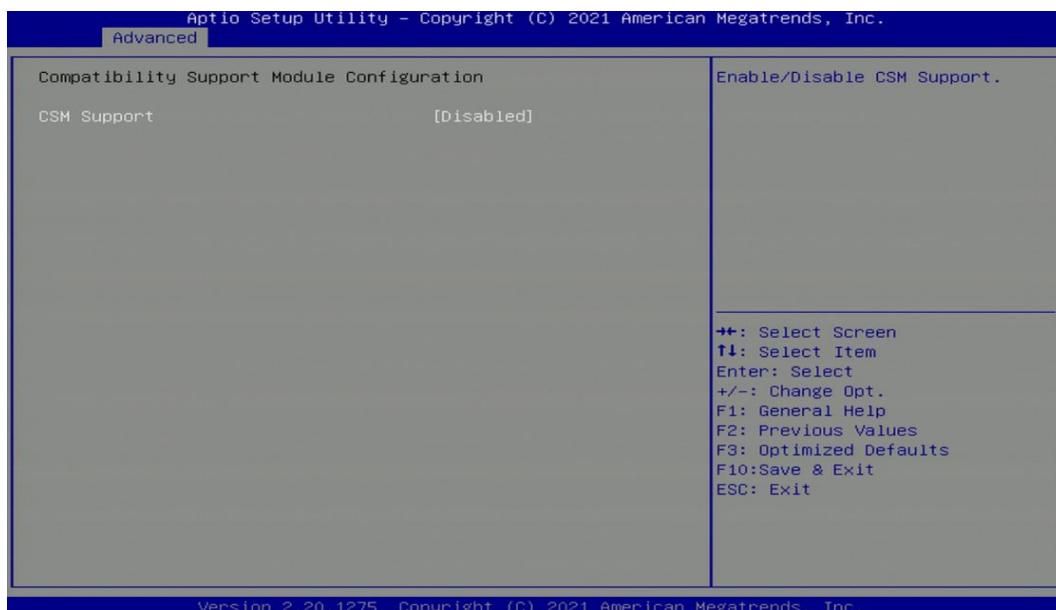

#### ■ CSM Support [Disabled]

Enables or disables compatibility support module.

### 4.3.11 Network Stack Configuration

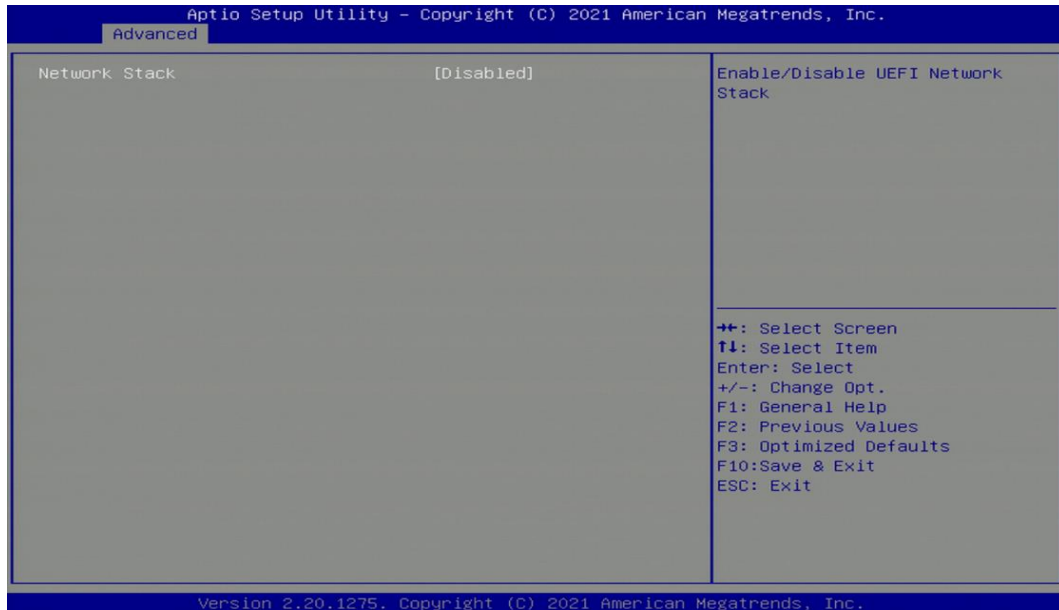

#### ■ Network Stack [Disabled]

Enables or disables UEFI Network Stack.

## 4.4 Chipset Setup

This section allows you to configure chipset related settings according to user's preference.

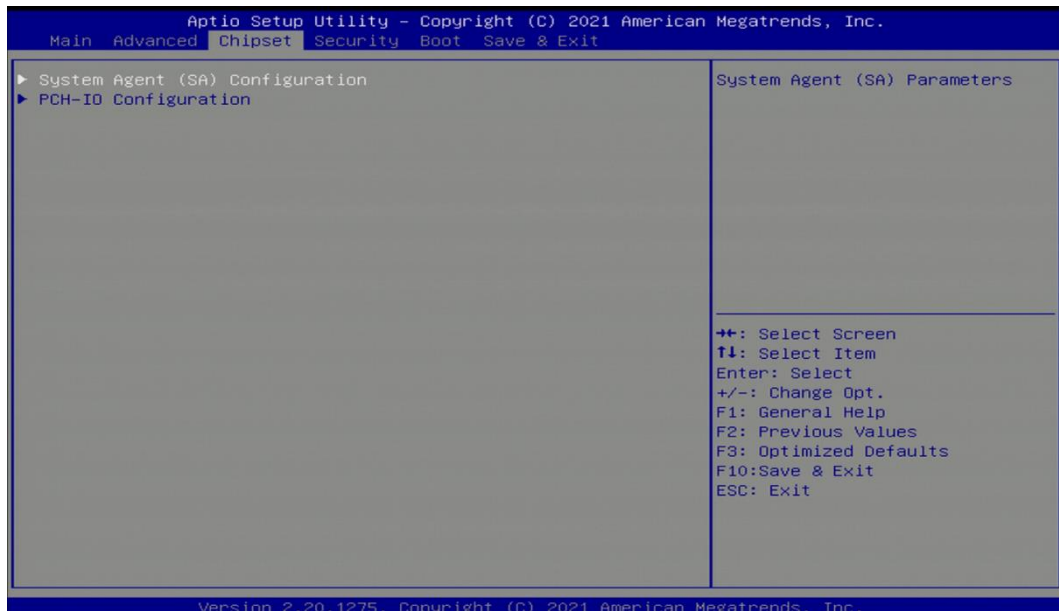

### 4.4.1 System Agent (SA) Configuration



## ■ Memory Configuration

This item displays detailed memory information in the system.

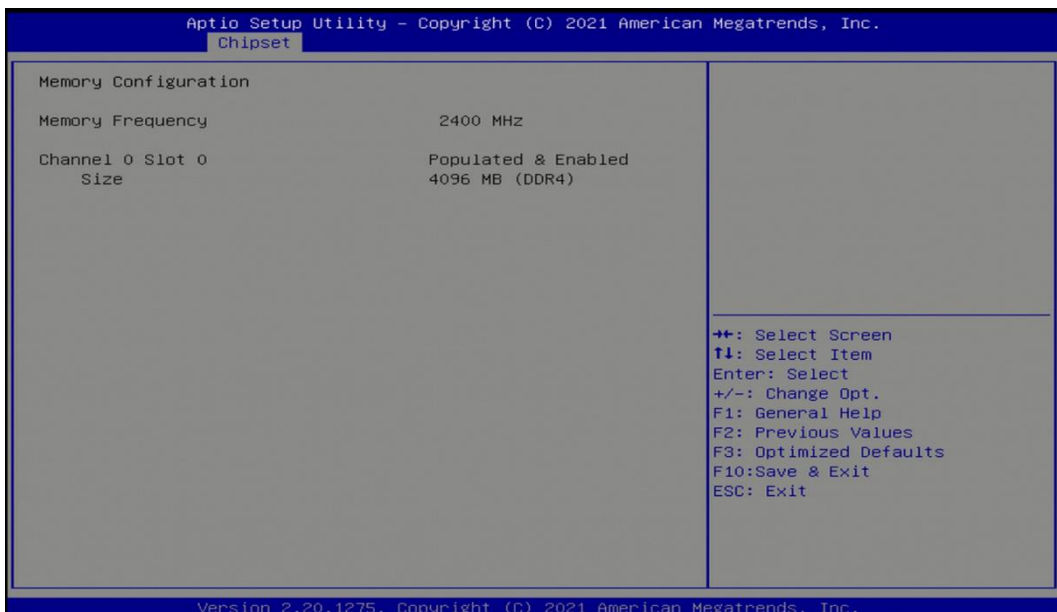

## ■ VT-d [Enabled]

This item allows users to enable or disable Intel® Virtualization Technology for Directed I/O (VT-d) function.

## 4.4.2 PCH-IO Configuration

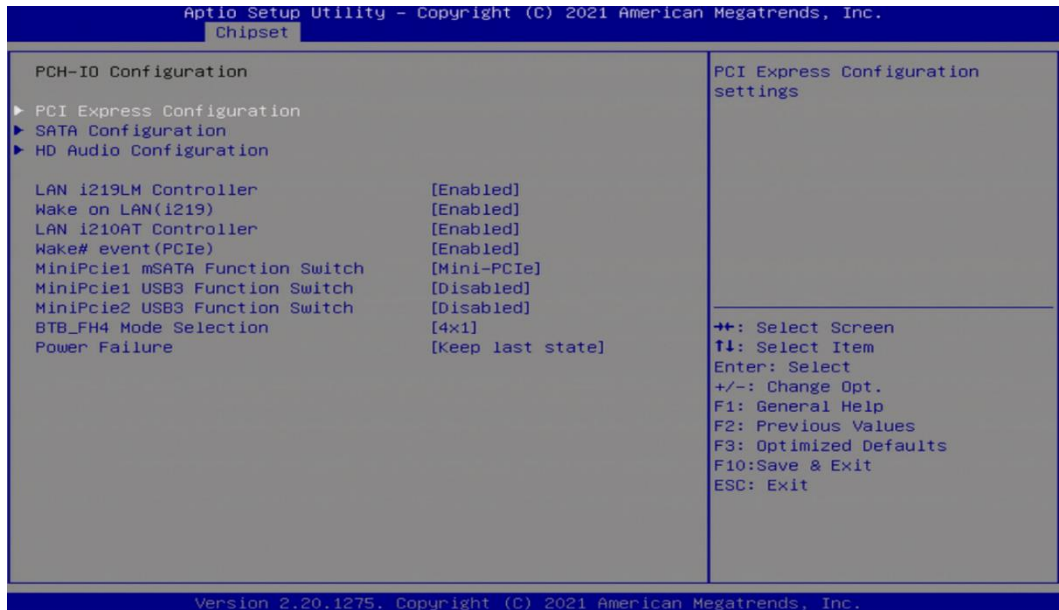

### ■ PCI Express Configuration

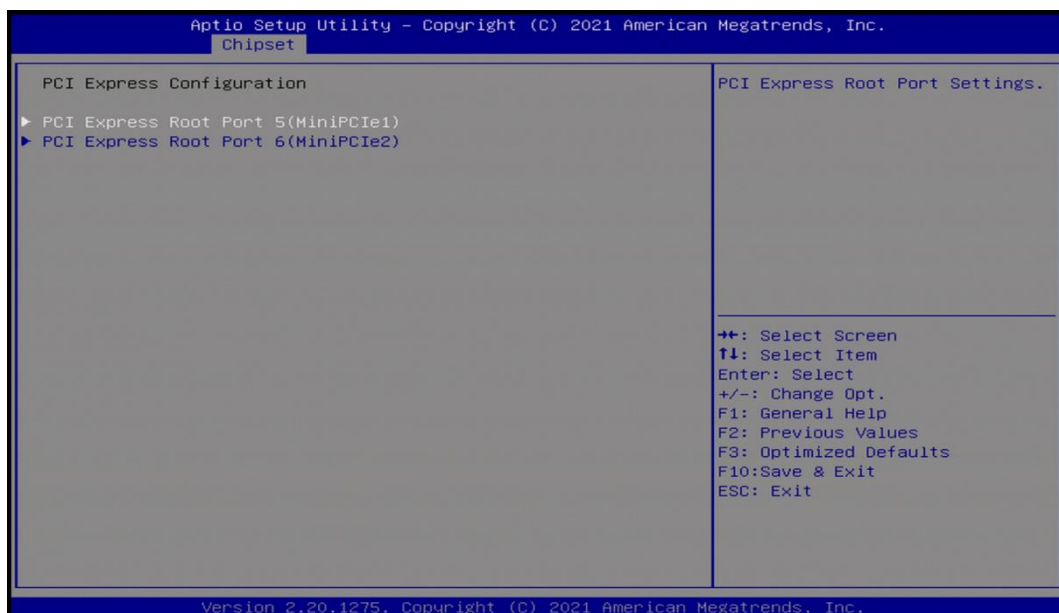

- ❑ **PCI Express Root Port 5 (MiniPCIe1)**
  - **PCI Express Root Port [Enabled]**

Allows you to enable or disable the PCI Express Port.
  - **PCIe Speed [Auto]**

Allows you to select PCI Express interface speed.  
Configuration options: [Auto] [Gen1] [Gen2] [Gen3].
- ❑ **PCI Express Root Port 6 (MiniPCIe2)**
  - **PCI Express Root Port [Enabled]**

Allows you to enable or disable the PCI Express Port.
  - **PCIe Speed [Auto]**

Allows you to select PCI Express interface speed.  
Configuration options: [Auto] [Gen1] [Gen2] [Gen3].

## ■ SATA Configuration

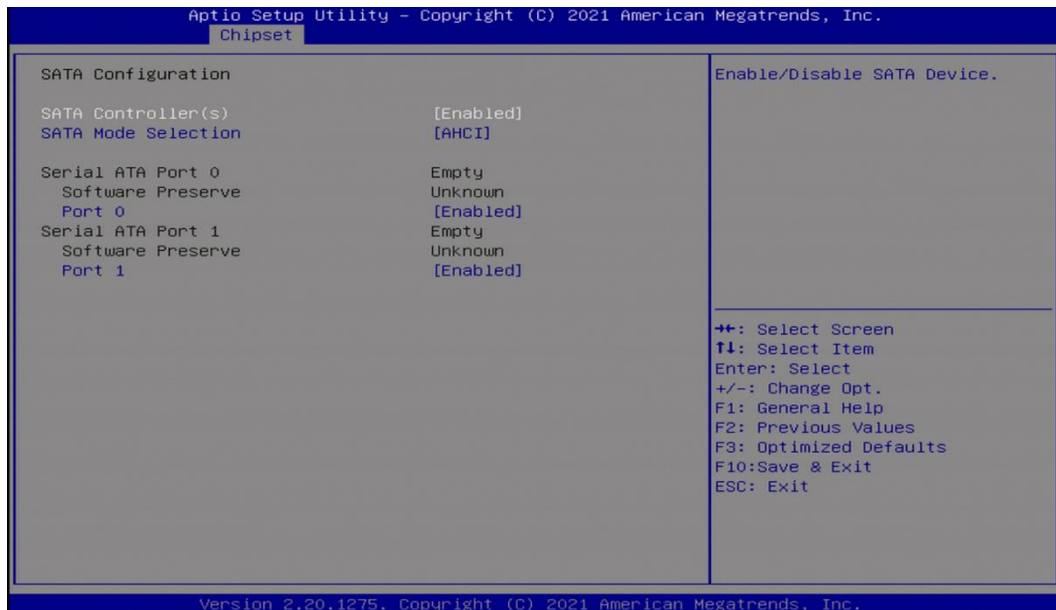

### ■ SATA Controller(s) [Enabled]

Enables or disables Serial ATA controller.

### ■ SATA Mode Selection [AHCI]

This item allows users to choose [AHCI] or [RAID] mode.

#### Serial ATA Port 0

##### Port 0 [Enabled]

Enables or disables SATA Port 0 (Location: SATA2).

#### Serial ATA Port 1

##### Port 1 [Enabled]

Enables or disables SATA Port 1 (Location: MINIPCIE1).

## ■ HD Audio Configuration

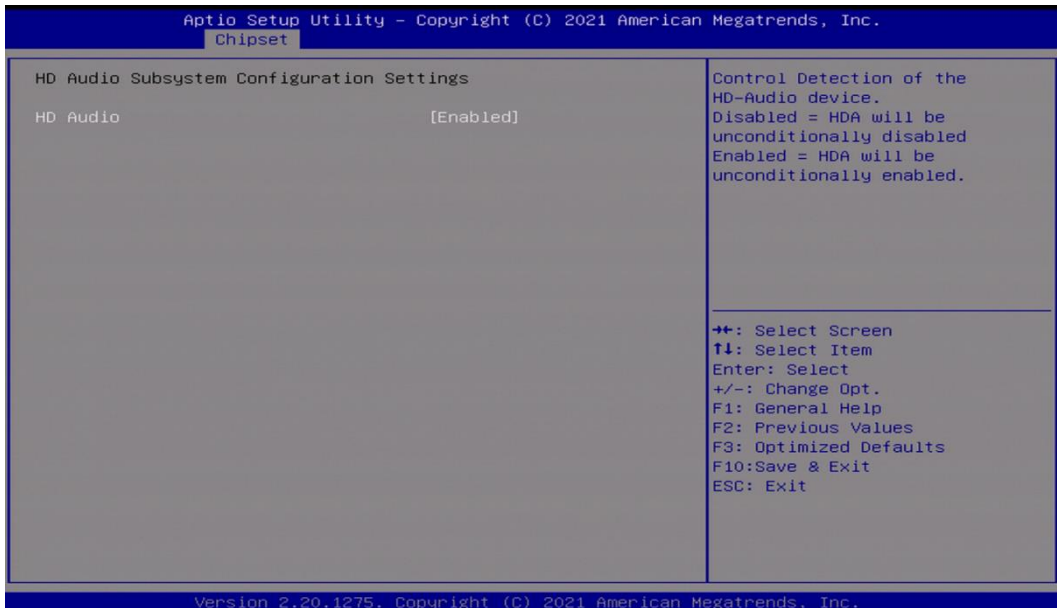

### □ HD Audio [Enabled]

Allows you to select HD Audio options.

[Enabled]: HD Audio device is unconditionally enabled.

[Disabled]: HD Audio device is unconditionally disabled.

### ■ LAN i219LM Controller [Enabled]

Enables or disables i219LM LAN Controller.

### ■ Wake On LAN (i219) [Enabled]

Enables or disables integrated LAN i219LM Wake on LAN function.

### ■ LAN i210AT Controller [Enabled]

Enables or disables I210 LAN Controller.

### ■ Wake# event (PCIe) [Enabled]

Enables or disables integrated LAN i210 Wake on LAN function.

### ■ MiniPcie1 mSATA Function Switch [Mini-PCIe]

Allows users to select [Mini-PCIe] or [mSATA] for MiniPCIe1 connector.

### ■ MiniPcie1 USB3 Function Switch [Disabled]

Enables or disables MiniPcie1 USB3 Function.

### ■ MiniPcie2 USB3 Function Switch [Disabled]

Enables or disables MiniPcie2 USB3 Function.

### ■ BTB\_FH4 Mode Selection [4x1]

Allows users to select [4x1] or [1x4] for BTB\_FH4 Mode.

### ■ Power Failure [Keep last state]

Allows you to specify which power state system will enter when power is resumed after a power failure (G3 state).

[Always on]: Enters to power on state.

[Always off]: Enters to power off state.

[Keep last state]: Enters to the last power state before a power failure.

## 4.5 Security Setup

This section allows users to configure BIOS security settings.

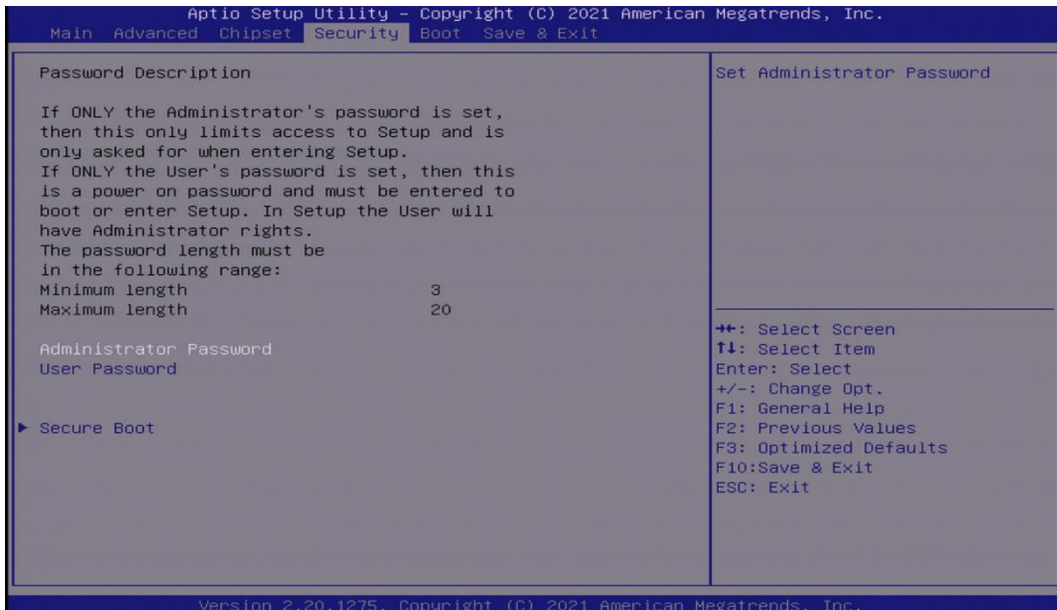

### 4.5.1 Administrator Password

Administrator Password controls access to the BIOS Setup utility.

### 4.5.2 User Password

User Password controls access to the system at boot and to the BIOS Setup utility.

### 4.5.3 Security Boot



- Secure Boot [Disabled]**  
Enable or disable Secure Boot function.
- Secure Boot Mode [Standard]**  
Allows you to select Secure Boot Mode.  
Configuration options: [Standard] [Custom].



## 4.6 Boot Setup

This section allows you to configure Boot settings.

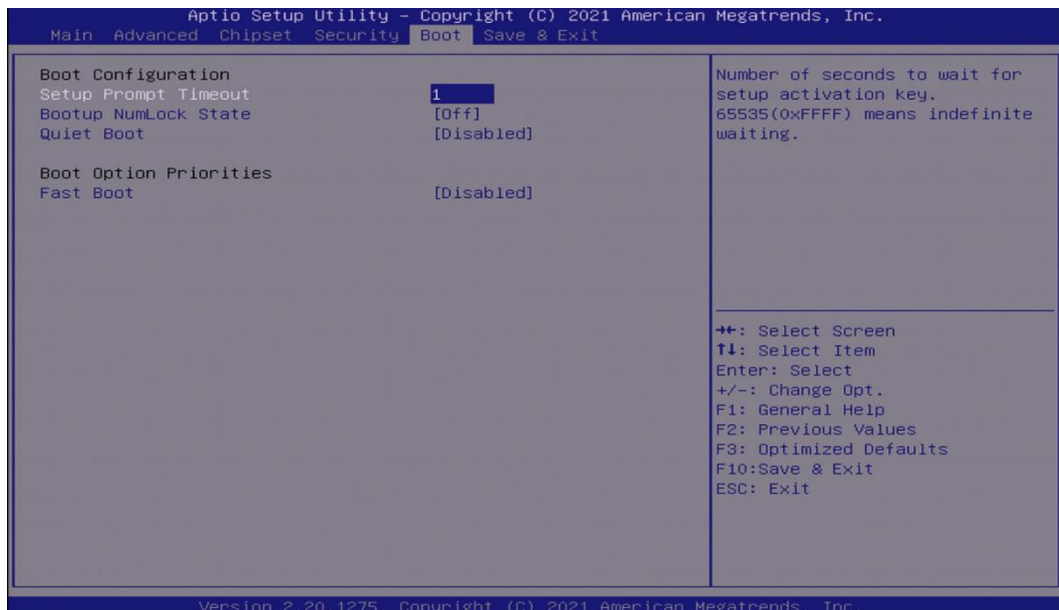

### 4.6.1 Setup Prompt Timeout [1]

Use this item to set number of seconds (1..65535) to wait for setup activation key.

### 4.6.2 Bootup NumLock State [Off]

Allows users to select the power-on state for keyboard NumLock.

### 4.6.3 Quiet Boot [Disabled]

Allows users to enable or disable Quiet Boot function.

### 4.6.4 Fast Boot [Disabled]

Allows users to enable or disable Fast Boot function.

## 4.7 Save & Exit

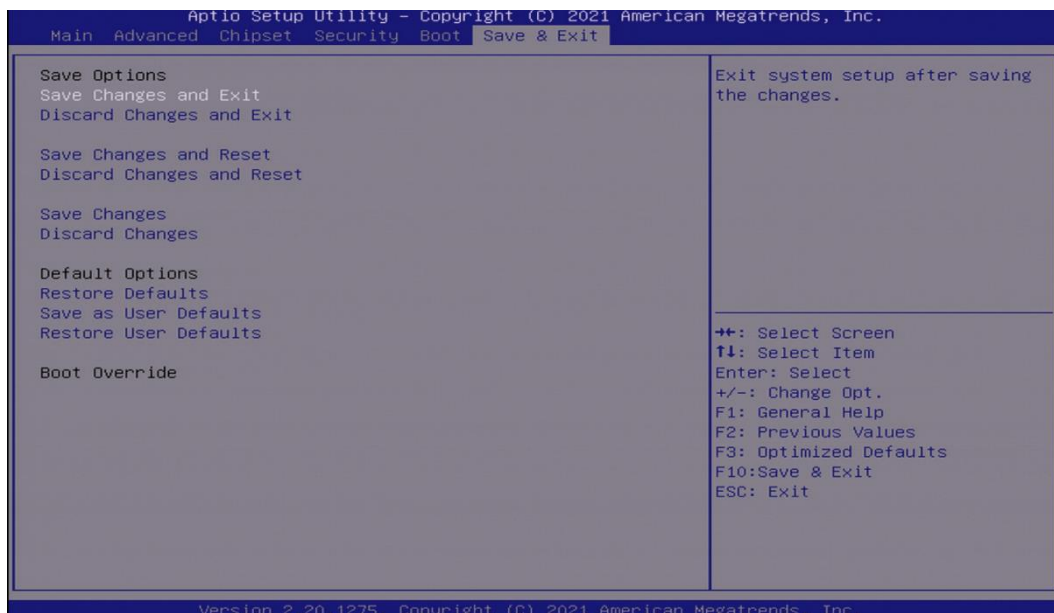

### 4.7.1 Save Changes and Exit

This item allows users to exit system setup after saving changes.

### 4.7.2 Discard Changes and Exit

This item allows users to exit system setup without saving changes.

### 4.7.3 Save Changes and Reset

This item allows users to reset the system after saving changes.

### 4.7.4 Discard Changes and Reset

This item allows users to reset system setup without saving any changes.

### 4.7.5 Save Changes

This item allows users to save changes done so far to any of the setup options.

### 4.7.6 Discard Changes

This item allows users to discard changes done so far to any of the setup options.

### 4.7.7 Restore Defaults

This item allows users to restore/ load default values for all the options.

### 4.7.8 Save as User Defaults

This item allows users to save the changes done so far as user defaults.

### 4.7.9 Restore User Defaults

This item allows users to restore the user defaults to all the options.



# **Chapter 5**

## **Product Application**

## 5.1 Digital I/O (DIO) application

This section describes DIO application of the product. The content and application development are better understood and implemented by well experienced professionals or developers.

### 5.1.1 Digital I/O Programming Guide

#### 5.1.1.1 Pins for Digital I/O

Item	Standard
GPIO30 (Pin36)	DI
GPIO31 (Pin37)	
GPIO32 (Pin38)	
GPIO33 (Pin39)	
GPIO34 (Pin40)	
GPIO35 (Pin41)	
GPIO36 (Pin42)	
GPIO37 (Pin43)	
GPIO50 (Pin9)	DO
GPIO51 (Pin10)	
GPIO52 (Pin11)	
GPIO53 (Pin12)	
GPIO54 (Pin13)	
GPIO55 (Pin14)	
GPIO56 (Pin15)	
GPIO57 (Pin16)	

### 5.1.1.2 Programming Guide

To program the Super I/O chip F81866A configuration registers, the following configuration procedures must be followed in sequence:

- (1) Enter the Extended Function Mode
- (2) Configure the configuration registers
- (3) Exit the Extended Function Mode

The configuration register is used to control the behavior of the corresponding devices. To configure the register, use the index port to select the index and then write data port to alter the parameters. The default index port and data port are 0x4E and 0x4F, respectively.

**Pull down the SOUT1 pin to change the default value to 0x2E/ 0x2F. To enable configuration, the entry key 0x87 must be written to the index port. To disable configuration, write exit entry key 0xAA to the index port.**

Following is an example to enable configuration and to disable configuration by using debug.

- o 4e 87
- o 4e 87 (enable configuration)
- o 4e aa (disable configuration)

### 5.1.1.3 Relative Registers

To program the F81866A configuration registers, see the following configuration procedures.

Logic Device Number Register (LDN) — Index 07h

Bit	Name	R/W	Reset	Default	Description
7-0	LDN	R/W	LRESET#	00h	00h: Select FDC device configuration registers. 03h: Select Parallel Port device configuration registers. 04h: Select Hardware Monitor device configuration registers. 05h: Select KBC device configuration registers. 06h: Select GPIO device configuration registers. 07h: Select WDT device configuration registers. 0Ah: Select PME, ACPI and ERP device configuration registers. 10h: Select UART1 device configuration registers. 11h: Select UART2 device configuration registers. 12h: Select UART3 device configuration registers. 13h: Select UART4 device configuration registers. 14h: Select UART5 device configuration registers. 15h: Select UART6 device configuration registers. Otherwise: Reserved.

**GPIO3 Output Enable Register — Index C0h**

Bit	Name	R/W	Reset	Default	Description
7	GPIO37_OE	R/W	LRESET#	0	0: GPIO37 is input. 1: GPIO37 is output.
6	GPIO36_OE	R/W	LRESET#	0	0: GPIO36 is input. 1: GPIO36 is output.
5	GPIO35_OE	R/W	LRESET#	0	0: GPIO35 is input. 1: GPIO35 is output.
4	GPIO34_OE	R/W	LRESET#	0	0: GPIO34 is input. 1: GPIO34 is output.
3	GPIO33_OE	R/W	LRESET#	0	0: GPIO33 is input. 1: GPIO33 is output.
2	GPIO32_OE	R/W	LRESET#	0	0: GPIO32 is input. 1: GPIO32 is output.
1	GPIO31_OE	R/W	LRESET#	0	0: GPIO31 is input. 1: GPIO31 is output.
0	GPIO30_OE	R/W	LRESET#	0	0: GPIO30 is input. 1: GPIO30 is output.

**GPIO3 Pin Status Register — Index C2h (This byte could be also read by base address + 9 if GPIO\_DEC\_RANGE is set to “1”)**

Bit	Name	R/W	Reset	Default	Description
7	GPIO37_IN	R	-	-	The pin status of SIN3/GPIO37.
6	GPIO36_IN	R	-	-	The pin status of SOUT3/GPIO36.
5	GPIO35_IN	R	-	-	The pin status of DSR3#/GPIO35.
4	GPIO34_IN	R	-	-	The pin status of RTS3#/GPIO34.
3	GPIO33_IN	R	-	-	The pin status of DTR3#/GPIO33.
2	GPIO32_IN	R	-	-	The pin status of CTS3#/GPIO32.
1	GPIO31_IN	R	-	-	The pin status of RI3#/GPIO31.
0	GPIO30_IN	R	-	-	The pin status of DCD3#/GPIO30.

### GPIO5 Output Enable Register — Index A0h

Bit	Name	R/W	Reset	Default	Description
7	GPIO57_OE	R/W	LRESET#	0	0: GPIO57 is in input mode. 1: GPIO57 is in output mode.
6	GPIO56_OE	R/W	LRESET#	0	0: GPIO56 is in input mode. 1: GPIO56 is in output mode.
5	GPIO55_OE	R/W	LRESET#	0	0: GPIO55 is in input mode. 1: GPIO55 is in output mode.
4	GPIO54_OE	R/W	LRESET#	0	0: GPIO54 is in input mode. 1: GPIO54 is in output mode.
3	GPIO53_OE	R/W	LRESET#	0	0: GPIO53 is in input mode. 1: GPIO53 is in output mode.
2	GPIO52_OE	R/W	LRESET#	0	0: GPIO52 is in input mode. 1: GPIO52 is in output mode.
1	GPIO51_OE	R/W	LRESET#	0	0: GPIO51 is in input mode. 1: GPIO51 is in output mode.
0	GPIO50_OE	R/W	LRESET#	0	0: GPIO50 is in input mode. 1: GPIO50 is in output mode.

### GPIO5 Output Data Register — Index A1h (This byte could be also written by base address + 5 )

Bit	Name	R/W	Reset	Default	Description
7	GPIO57_DATA	R/W	LRESET#	1	0: GPIO57 outputs 0 when in output mode. 1: GPIO57 outputs 1 when in output mode.
6	GPIO56_DATA	R/W	LRESET#	1	0: GPIO56 outputs 0 when in output mode. 1: GPIO56 outputs 1 when in output mode.
5	GPIO55_DATA	R/W	LRESET#	1	0: GPIO55 outputs 0 when in output mode. 1: GPIO55 outputs 1 when in output mode.
4	GPIO54_DATA	R/W	LRESET#	1	0: GPIO54 outputs 0 when in output mode. 1: GPIO54 outputs 1 when in output mode.
3	GPIO53_DATA	R/W	LRESET#	1	0: GPIO53 outputs 0 when in output mode. 1: GPIO53 outputs 1 when in output mode.
2	GPIO52_DATA	R/W	LRESET#	1	0: GPIO52 outputs 0 when in output mode. 1: GPIO52 outputs 1 when in output mode.
1	GPIO51_DATA	R/W	LRESET#	1	0: GPIO51 outputs 0 when in output mode. 1: GPIO51 outputs 1 when in output mode.
0	GPIO50_DATA	R/W	LRESET#	1	0: GPIO50 outputs 0 when in output mode. 1: GPIO50 outputs 1 when in output mode.

### 5.1.1.4 Sample Code in C Language

#### 5.1.1.4.1 Control of GP30 to GP37 (DI1 ~ DI8)

```
#define AddrPort 0x4E
```

```
#define DataPort 0x4F
```

<Enter the Extended Function Mode>

```
WriteByte(AddrPort, 0x87)
```

```
WriteByte(AddrPort, 0x87)           // Must write twice to enter Extended mode
```

<Select Logic Device>

```
WriteByte(AddrPort, 0x07)
```

```
WriteByte(dataPort, 0x06)         // Select logic device 06h
```

<Output/Input Mode Selection> // Set GP30 to GP37 input Mode

```
WriteByte(AddrPort, 0xC0)         // Select configuration register C0h
```

```
WriteByte(DataPort, 0x00)         // Set (bit 0~7) = 0 to select GP 30~37 as Input mode.
```

<Input Value>

```
WriteByte(AddrPort, 0xC2)         // Select configuration register C2h
```

```
ReadByte(DataPort, Value) // Assume read (bit 0~7) to Value is FFh , thus GP30 ~37 are all high.
```

```
                                // Assume read (bit 0~7) to Value is 00h , thus GP30 ~37 are all low.
```

```
                                // Read Value range: 00h~FFh
```

<Leave the Extended Function Mode>

```
WriteByte(AddrPort, 0xAA)
```



#### 5.1.1.4.2 Control of GP50 to GP57 (DO1 ~ DO8)

```
#define AddrPort 0x4E

#define DataPort 0x4F

<Enter the Extended Function Mode>

WriteByte(AddrPort, 0x87)

WriteByte(AddrPort, 0x87) // Must write twice to enter Extended mode

<Select Logic Device>

WriteByte(AddrPort, 0x07)

WriteByte(DataPort, 0x06) // Select logic device 06h

<Output/Input Mode Selection> // Set GP50 to GP57 output Mode

WriteByte(AddrPort, 0xA0) // Select configuration register A0h

WriteByte(DataPort, 0xFF) // Set (bit 0~7) = 1 to select GP 50 ~57 as Output mode.

<Output Value>

WriteByte(AddrPort, 0xA1) // Select configuration register A1h

WriteByte(DataPort, Value) // Set bit 0~7=(0/1) to output GP 50~57 as Low or High

// Write Value Range: 0x00 ~0xFF

<Leave the Extended Function Mode>

WriteByte(AddrPort, 0xAA)
```

### 5.1.1.5 Change base address

<Enter the Extended Function Mode>

```
WriteByte(AddrPort, 0x87)
```

```
WriteByte(AddrPort, 0x87) // Must write twice to enter Extended mode
```

<Select Logic Device>

```
WriteByte(AddrPort, 0x07)
```

```
WriteByte(dataPort, 0x06) // Select logic device 06h
```

```
WriteByte(AddrPort, 0x60) // Select configuration register 60h (High Byte address)
```

```
WriteByte(DataPort, 0x0A)
```

```
WriteByte(AddrPort, 0x61) // Select configuration register 61h (Low Byte address)
```

```
WriteByte(DataPort, 0x00)
```

<Leave the Extended Function Mode>

```
WriteByte(AddrPort, 0xAA)
```

Cincoze default GPIO Port base address is 0xA00

### 5.1.1.6 DATA Bit Table (DIO)

7	6	5	4	3	2	1	0	bit
0	0	0	0	0	0	0	1	Value
1								/h

= DI1

(Base  
address +9)  
(0xA09)

7	6	5	4	3	2	1	0	bit
0	0	0	0	0	0	0	1	Value
1								/h

= DO1

(Base  
address +5)  
(0xA05)

7	6	5	4	3	2	1	0	bit
0	0	0	0	0	0	1	0	Value
2								/h

= DI2

(Base  
address +9)  
(0xA09)

7	6	5	4	3	2	1	0	bit
0	0	0	0	0	0	1	0	Value
2								/h

= DO2

(Base  
address +5)  
(0xA05)

7	6	5	4	3	2	1	0	bit
0	0	0	0	0	1	0	0	Value
4								/h

= DI3

(Base  
address +9)  
(0xA09)

7	6	5	4	3	2	1	0	bit
0	0	0	0	0	1	0	0	Value
4								/h

= DO3

(Base  
address +5)  
(0xA05)

7	6	5	4	3	2	1	0	bit
0	0	0	0	1	0	0	0	Value
8								/h

= DI4

(Base  
address +9)  
(0xA09)

7	6	5	4	3	2	1	0	bit
0	0	0	0	1	0	0	0	Value
8								/h

= DO4

(Base  
address +5)  
(0xA05)

7	6	5	4	3	2	1	0	bit
0	0	0	1	0	0	0	0	Value
10								/h

= DI5

(Base  
address +9)  
(0xA09)

7	6	5	4	3	2	1	0	bit
0	0	0	1	0	0	0	0	Value
10								/h

= DO5

(Base  
address +5)  
(0xA05)

7	6	5	4	3	2	1	0	bit
0	0	1	0	0	0	0	0	Value
20								/h

= DI6

(Base  
address +9)  
(0xA09)

7	6	5	4	3	2	1	0	bit
0	0	1	0	0	0	0	0	Value
20								/h

= DO6

(Base  
address +5)  
(0xA05)

7	6	5	4	3	2	1	0	bit
0	1	0	0	0	0	0	0	Value
40								/h

= DI7

(Base  
address +9)  
(0xA09)

7	6	5	4	3	2	1	0	bit
0	1	0	0	0	0	0	0	Value
40								/h

= DO7

(Base  
address +5)  
(0xA05)

7	6	5	4	3	2	1	0	bit
1	0	0	0	0	0	0	0	Value
80								/h

= DI8

(Base  
address +9)  
(0xA09)

7	6	5	4	3	2	1	0	bit
1	0	0	0	0	0	0	0	Value
80								/h

= DO8

(Base  
address +5)  
(0xA05)

### 5.1.1.7 DIO I/O Port Address (Default Address 0xA00)

Pin Definition	DI8	DI7	DI6	DI5	DI4	DI3	DI3	DI1
Data Bits	7	6	5	4	3	3	1	0
DIO Type	Digital Input							
I/O Port Address	0xA09							

Pin Definition	DO8	DO7	DO6	DO5	DO4	DO3	DO3	DO1
Data Bits	7	6	5	4	3	3	1	0
DIO Type	Digital Output							
I/O Port Address	0xA05							

## 5.2 DIO Hardware Specification

- XCOM+/ 2XCOM+: Isolated power in V+
- XCOM-/ 2XCOM-: Isolated power in V-
- Isolated power in DC voltage: 9-30V
- 8x / 16x Digital Input (Source Type)
- Input Signal Voltage Level
  - Signal Logic 0: XCOM+ = 9V,  $\text{Signal Low} - V_- < 1V$   
XCOM+ > 9V,  $V_+ - \text{Signal Low} > 8V$
  - Signal Logic 1:  $> \text{XCOM+} - 3V$
- Input Driving Sink Current:
  - Minimal: 1 mA
  - Normal: 5 mA
- 8x / 16x Digital Output (Open Drain)
  - DO Signal have to pull up resistor to XCOM+ for external device, the resistance will affect the pull up current
  - Signal High Level: Pull up resistor to XCOM+
  - Signal Low Level: = XCOM-
  - Sink Current: 1A (Max)

## 5.2.1 DIO Connector Definition

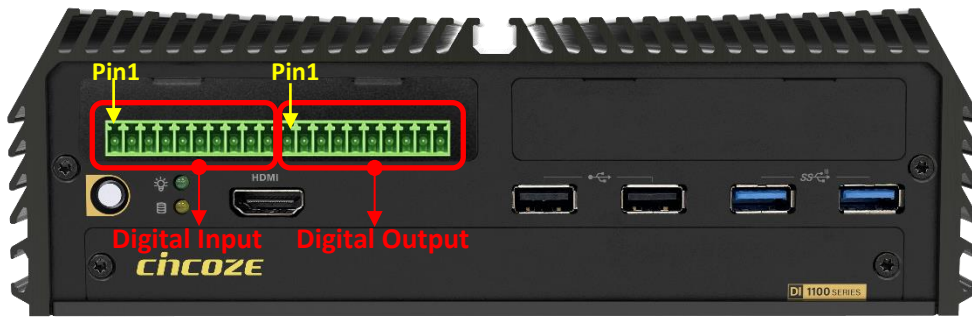

### Digital Input/ Output Connector

Connector Type: Terminal Block 2X10 20-pin, 3.5mm pitch

Location	Pin	Definition
Digital Input	1	DC INPUT (XCOM+)
	2	DI1
	3	DI2
	4	DI3
	5	DI4
	6	DI5
	7	DI6
	8	DI7
	9	DI8
	10	GND (XCOM-)

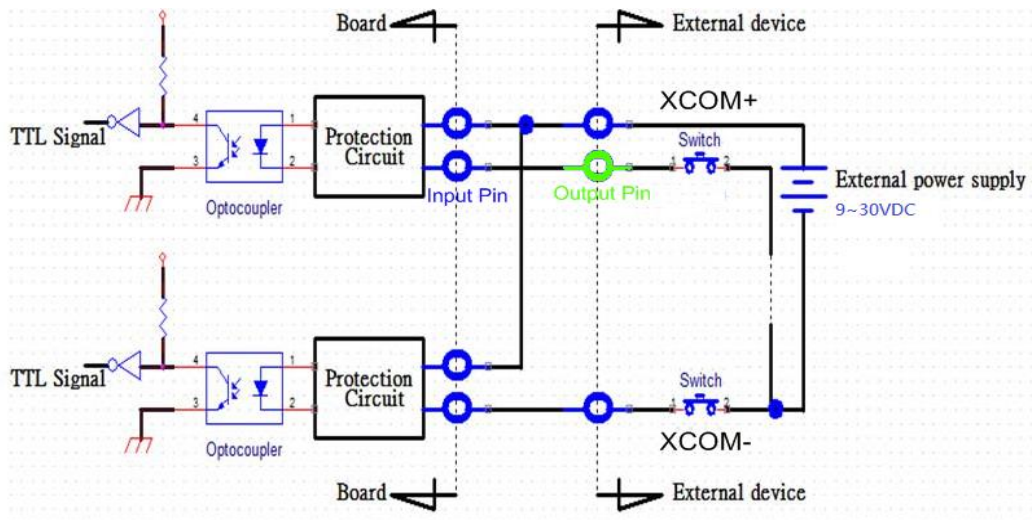

Location	Pin	Definition
Digital Output	1	DC INPUT (XCOM+)
	2	DO1
	3	DO2
	4	DO3
	5	DO4
	6	DO5
	7	DO6
	8	DO7
	9	DO8
	10	GND (XCOM-)

## Reference Input Circuit

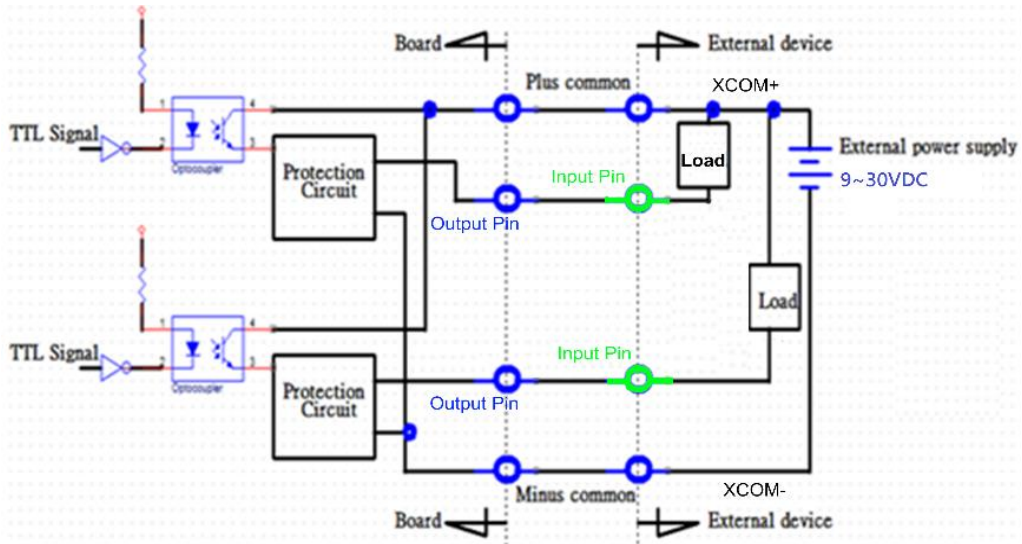

## Reference Output Circuit





# **Chapter 6**

## **Optional Modules & Accessories**



# 6.1 Optional Module Pin Definition & Settings

## 6.1.1 CMI-M12LAN01-R12/UB1510-R10 Module

### CMI-M12 LAN Module Pin Definitions

Connector Type: M12 A-coded 8pin connector

Pin	Definition	Pin	Definition
1	2_LAN1_0+	2	2_LAN1_0-
3	2_LAN1_1+	4	2_LAN1_2+
5	2_LAN1_2-	6	2_LAN1_1-
7	2_LAN1_3+	8	2_LAN1_3-

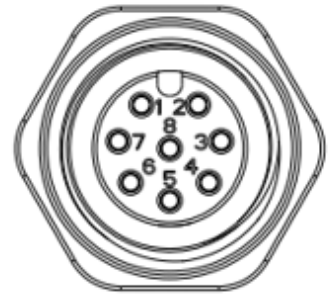

## 6.1.2 CMI-XM12LAN01-R10/UB1510-R10 Module

### CMI-XM12LAN01 Module Pin Definitions

Connector Type: M12 X-coded 8pin connector

Pin	Definition	Pin	Definition
1	D1+	2	D1-
3	D2+	4	D2-
5	D4+	6	D4-
7	D3-	8	D3+

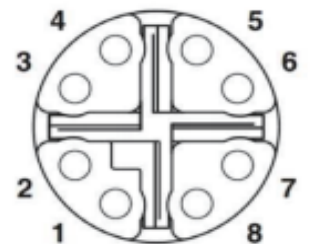

### 6.1.3 CMI-10GLAN04-R10/UB1528-R10 Module

#### LAN LED Definition

Link LED Status	Definition
Steady Green	10 Gbps Network Link
Steady Orange	1Gbps Network Link
Off	100Mbps Network Link

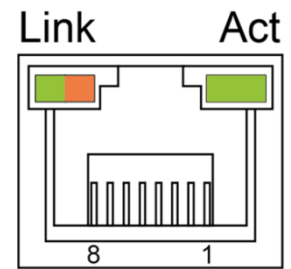

Act LED Status	Definition
Blinking Green	Data Activity
Steady Green	No Activity

## 6.1.4 CMI-COM05-R10/UB1503-R10 Module

### COM3~COM4 : RS232/ RS422/ RS485 Connector

Connector Type: 9-pin D-Sub

Pin	RS232 Definition	RS422/ RS485 Full Duplex Definition	RS485 Half Duplex Definition
1	DCD	TX-	DATA -
2	RXD	TX+	DATA +
3	TXD	RX+	
4	DTR	RX-	
5	GND		
6	DSR		
7	RTS		
8	CTS		
9	RI		



### MODE3 on CMI-COM05 Module : COM3 Power Select

Location	Function	DIP1	DIP2	
MODE3	COM3	0V(RI)	ON (Default)	ON (Default)
		5V	OFF	ON
		12V	OFF	OFF



ON  
OFF

### MODE4 on CMI-COM05 Module : COM4 Power Select

Location	Function	DIP1	DIP2	
MODE4	COM4	0V(RI)	ON (Default)	ON (Default)
		5V	OFF	ON
		12V	OFF	OFF

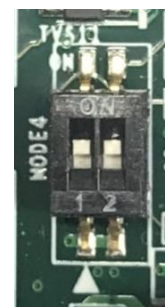

ON  
OFF

## 6.1.5 CFM-IGN102 Module

### SW2 : IGN Module Timing Setting Switch

Set shutdown delay timer when ACC is turned off

Pin 1	Pin 2	Pin 3	Pin 4	Definition
ON (IGN Enabled) / OFF (IGN Disabled)	ON	ON	ON	0 second
	ON	ON	OFF	1 minute
	ON	OFF	ON	5 minutes
	ON	OFF	OFF	10 minutes
	OFF	ON	ON	30 minutes
	OFF	ON	OFF	1 hour
	OFF	OFF	ON	2 hours
	OFF	OFF	OFF	Reserved (0 second)

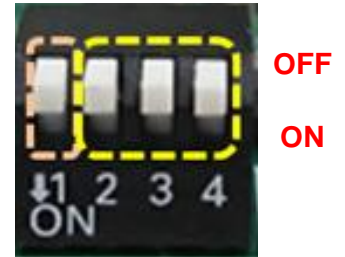

Default setting of Pin1 to Pin4 is OFF/ OFF/ OFF/ OFF.

### 24V\_12V\_1 : IGN Module Voltage Mode Setting Switch

#### 12V/ 24V Car Battery Switch

Switch	Definition
Left	12V Car Battery Input
Right	24V Car Battery Input (Default)



## 6.2 Installing High Speed CMI Module

### 6.2.1 CMI-LAN01-R12/UB1512-R10 Module

1. Loosen the 2 screws and remove the front bezel.



2. Locate the BTB\_FH1 connector of the CMI module on the top side of system.



3. Insert the CMI module vertically until it's connected firmly and fasten 2 screws to fix it.

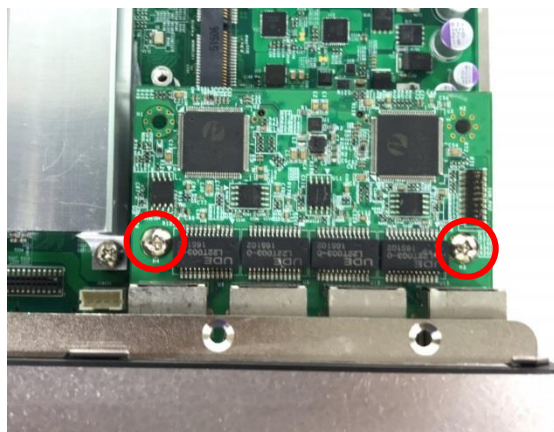

4. Attach the I/O bracket on to the system, and fasten the two screws to fix it.

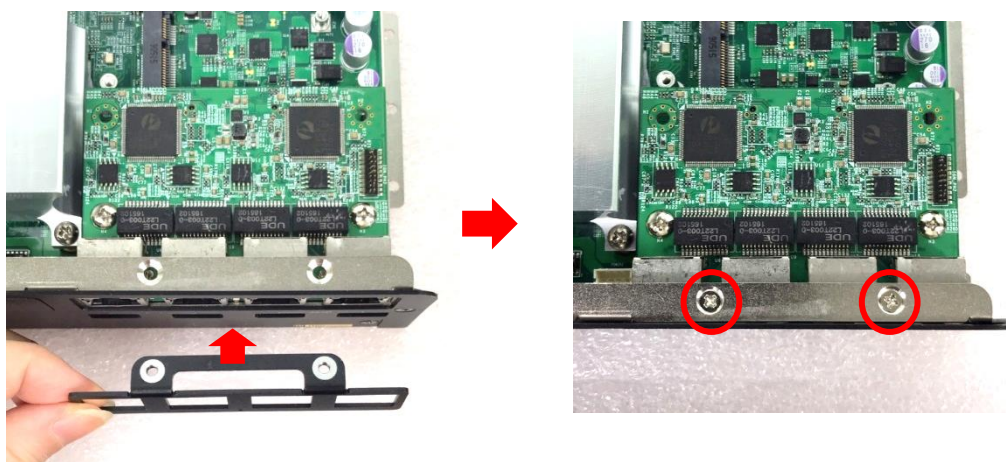

## 6.2.2 CMI-M12LAN01-R12/UB1510-R10 Module

1. Loosen the 2 screws and remove the front bezel.

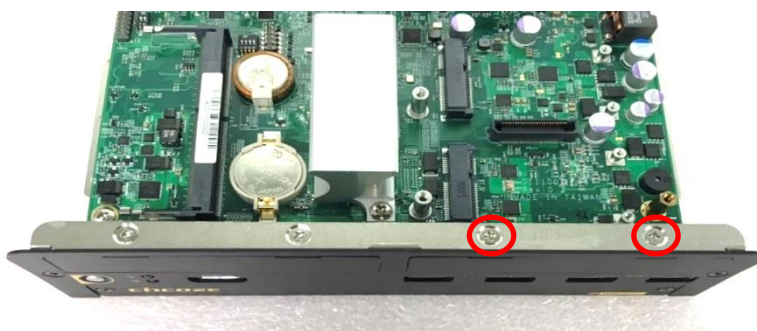

2. Locate the BTB\_FH1 connector of the CMI module on the top side of system.



3. Remove the four hex rings from the CMI-M12LAN module.

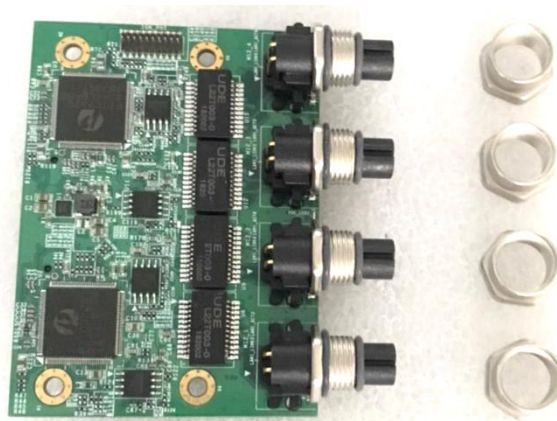

4. Insert the CMI module vertically until it's connected firmly and fasten 2 screws to fix it.

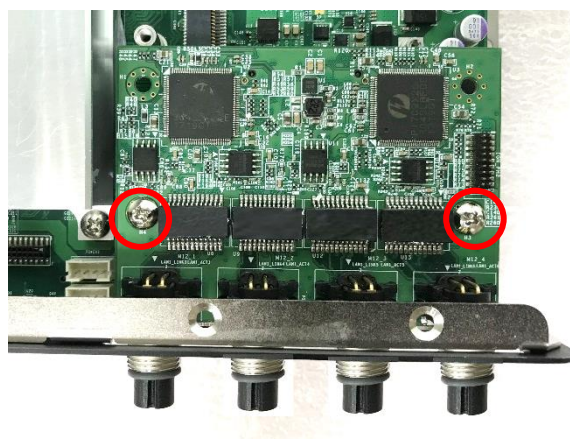

5. Attach the I/O bracket on to the system, and fasten the two screws to fix it.

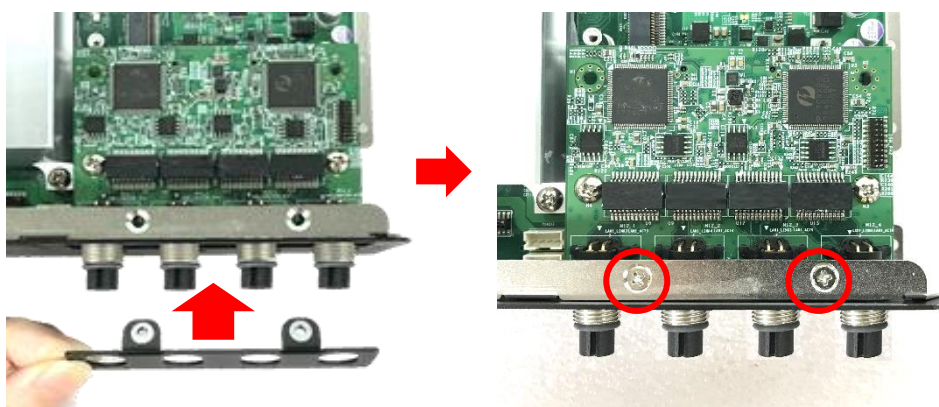

6. Fasten the four hex rings to fix the cover plate.



### 6.2.3 CMI-XM12LAN01-R10/UB1510-R10 Module



Hex washers



M12 I/O bracket



Hex rings



Rubber rings



1. Assemble the hex rings, M12 I/O bracket and hex washers together as indicated below:  
Penetrate hex rings through the M12 I/O bracket holes, and fix them with hex washers.



2. Loosen the 2 screws and remove the front bezel.



3. Locate the BTB\_FH1 connector of the CMI module on the top side of system.



4. Insert the CMI module vertically into the female connector on system's mainboard until it's connected firmly and fasten 2 screws to fix it.

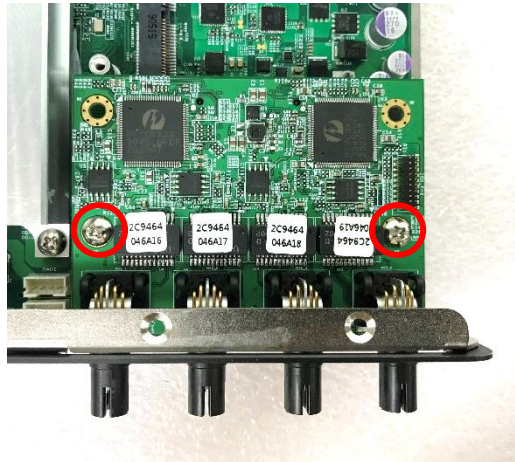

5. Attach the assembled M12 I/O bracket on to the system, and fasten the hex nuts to fix it.

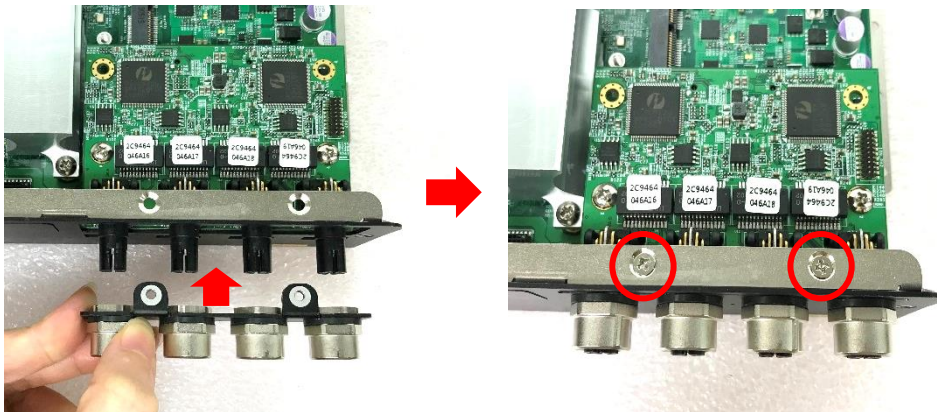

6. Put on the rubber rings to the four M12 LAN ports.

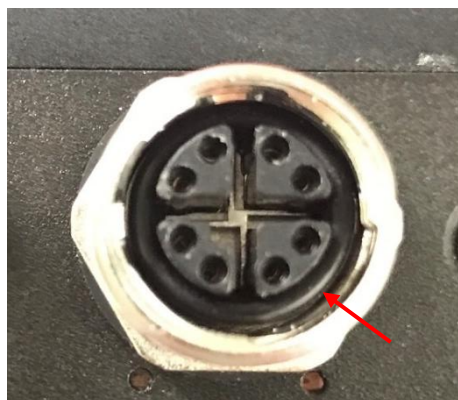

## 6.2.4 CMI-10GLAN04-R10/UB1528-R10 Module

Before installing CMI-10GLAN04-R10 module, users need to enter BIOS to complete the following setting first. When entering BIOS, get to Chipset > PCH-IO Configuration page, and change the [BTB\_FH4 Mode Selection] setting from default mode [4x1] to mode [1x4].

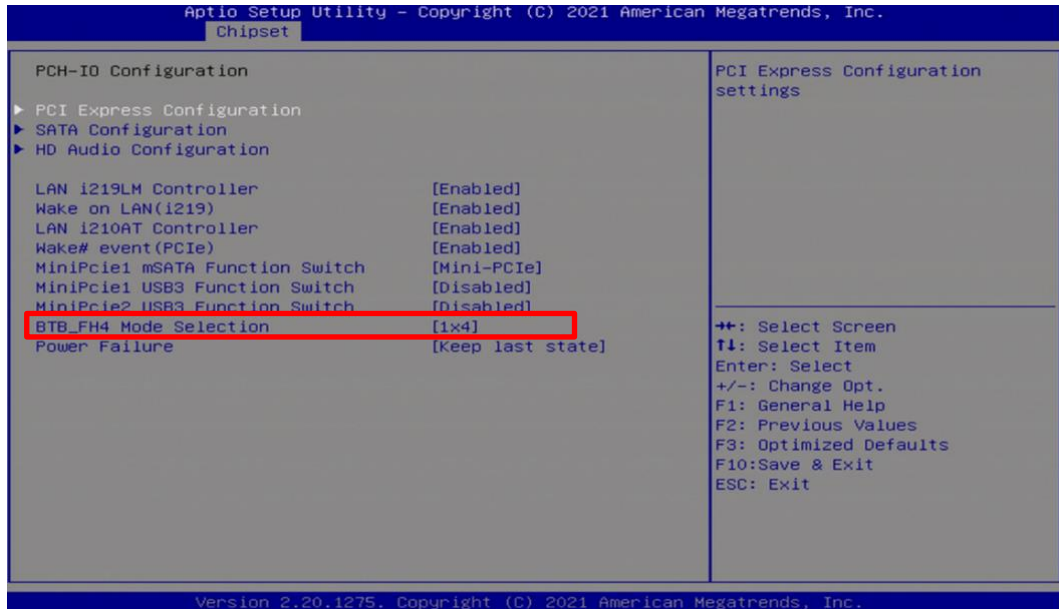

1. Loosen the 2 screws and remove the front bezel.



2. Locate the BTB\_FH1 connector of the CMI module on the top side of system.

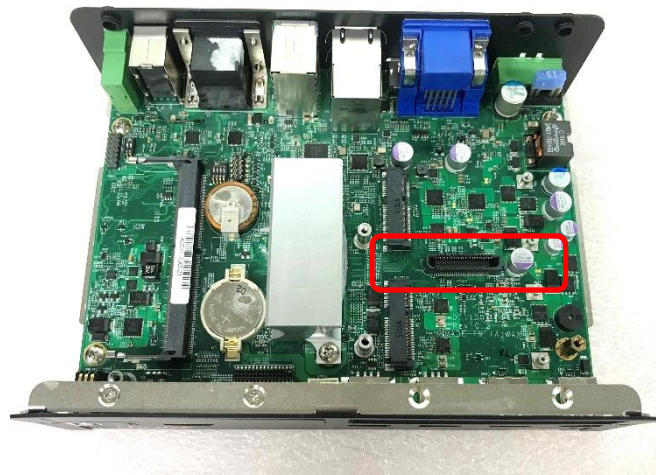

3. Locate the chip place on the CMI-10GLAN module marked by red square. Paste the thermal pad on it carefully.

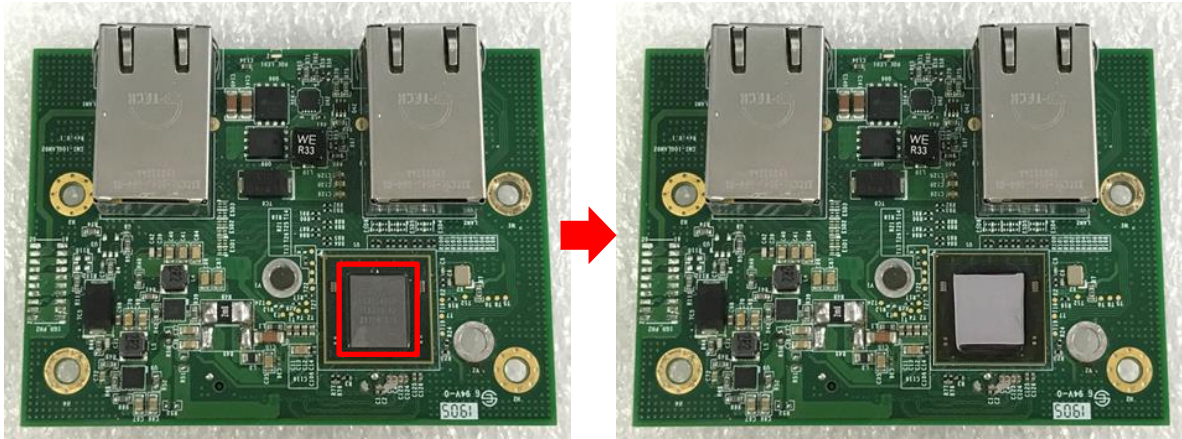

**CAUTION**

**Before putting on the heatsink (in the next step), please make sure the protective film on the Thermal Pad has been removed!**

4. Put on the heatsink and turn over the module. Fasten the 3 screws (M3X5L) to fix the heatsink.

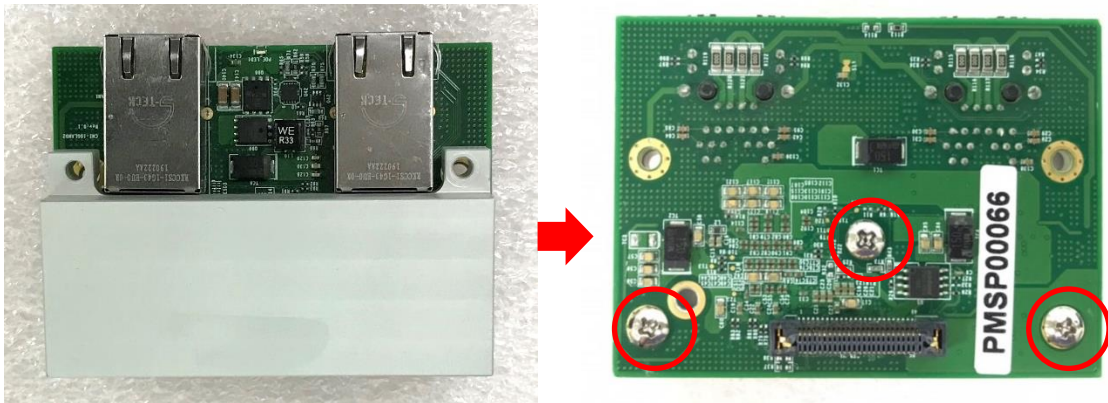

5. Insert the CMI module vertically into the female connector on system's mainboard until it's connected firmly and fasten the 2 screws (M3X12L) to fix it.

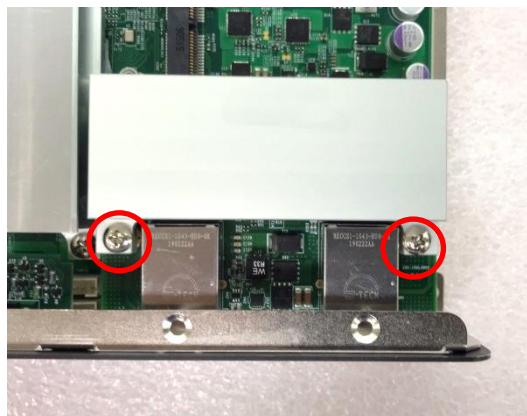

6. Paste the thermal pad onto the heatsink carefully.

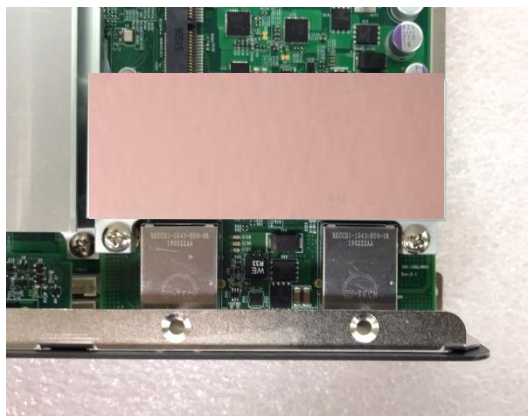

CAUTION

**Before assembling the system's chassis cover, please make sure the transparent protective film on the Thermal Pad has been removed!**

7. Attach the I/O bracket on to the system, and fasten the two screws to fix it.

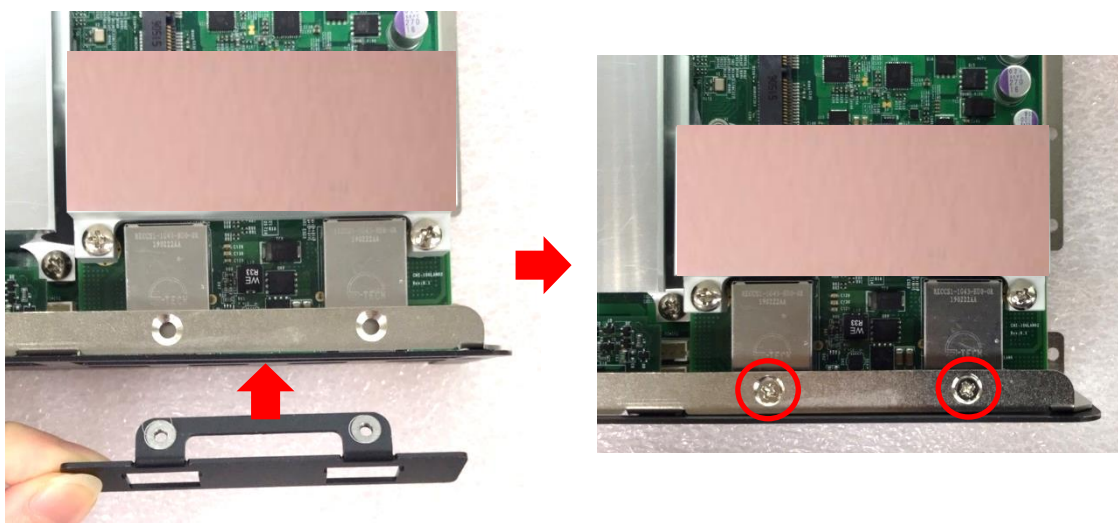

## 6.3 Installing Low Speed CMI Module

### 6.3.1 CMI-DIO05-R10/UB1518-R10 Module

1. Loosen the 2 screws and remove the front bezel.



2. Locate the BTB\_FH2 connector of the CMI module on the top side of system.

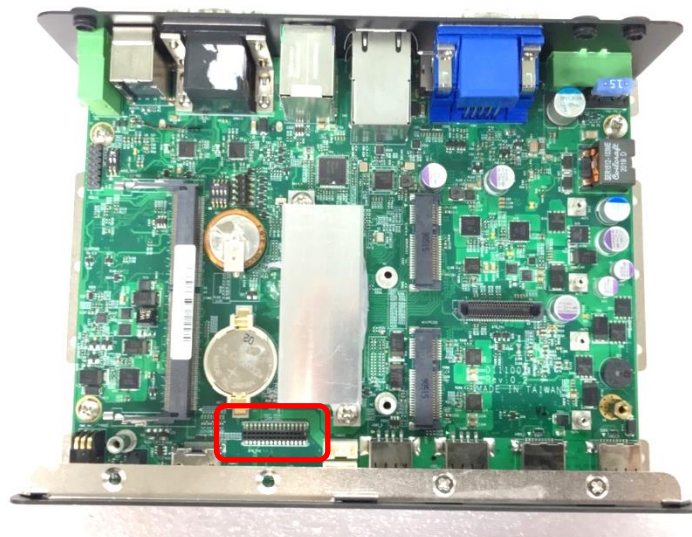

3. Insert the CMI module vertically until it's connected firmly and fasten the screw to fix it.



- Attach the I/O bracket on to the system, and fasten the two screws to fix it.

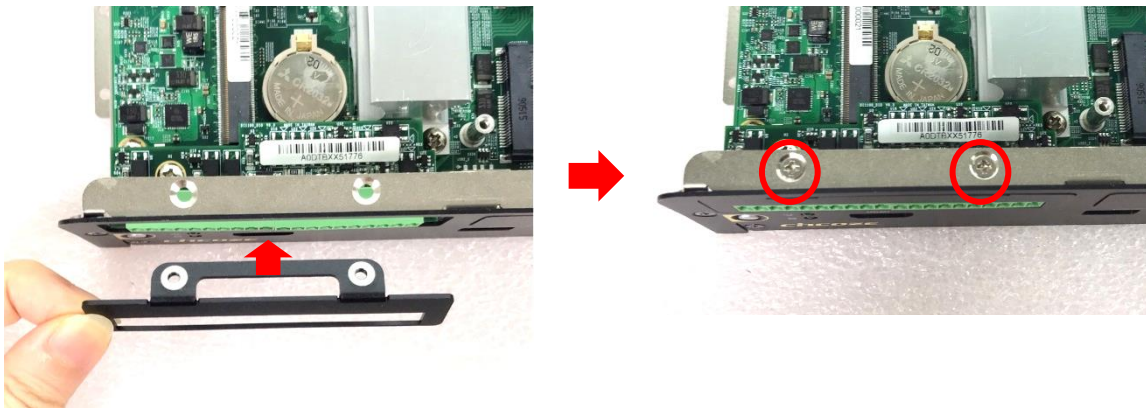

### 6.3.2 CMI-COM05-R10/UB1503-R10 Module

After installing CMI-COM05-R10 module, users need to enter BIOS to check the items for CMI-COM05-R10 module, which are “Serial Port 3 Configuration” and “Serial Port 4 Configuration”. Please find Chapter 4.3.5 for the detail setup regulations.

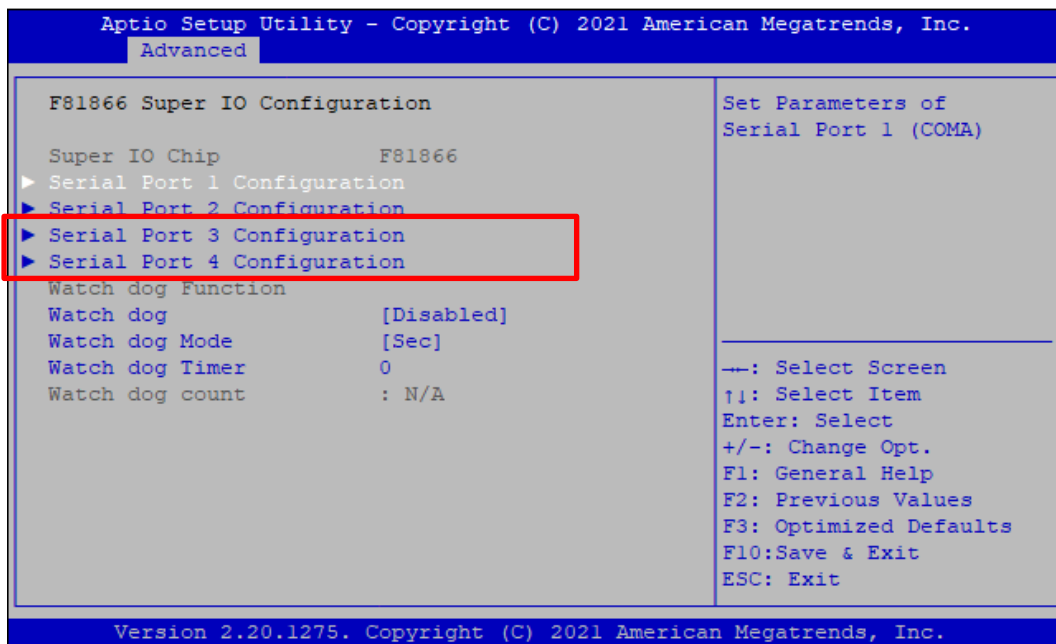

1. Loosen the 2 screws and remove the front bezel.



2. Locate the BTB\_FH2 connector of the CMI module on the top side of system.

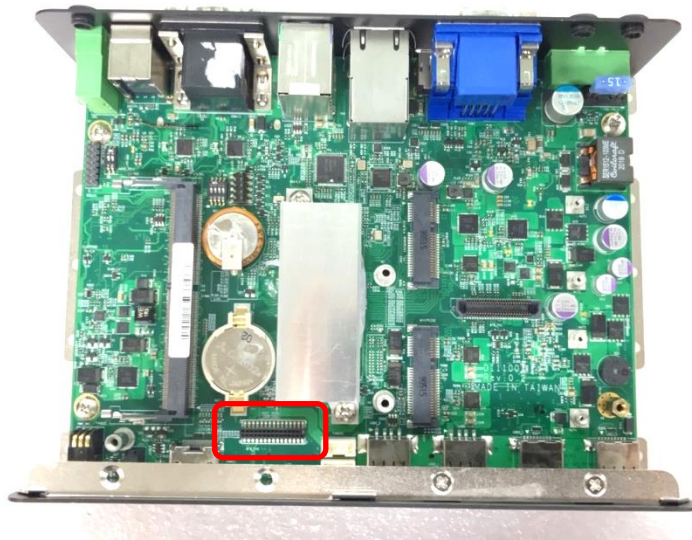

3. Insert the CMI module vertically until it's connected firmly and fasten the screw to fix it.

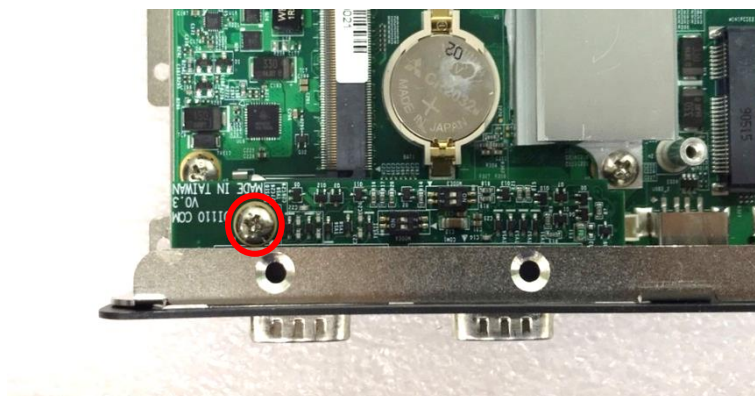



4. Attach the I/O bracket on to the system, and fasten the two screws to fix it.

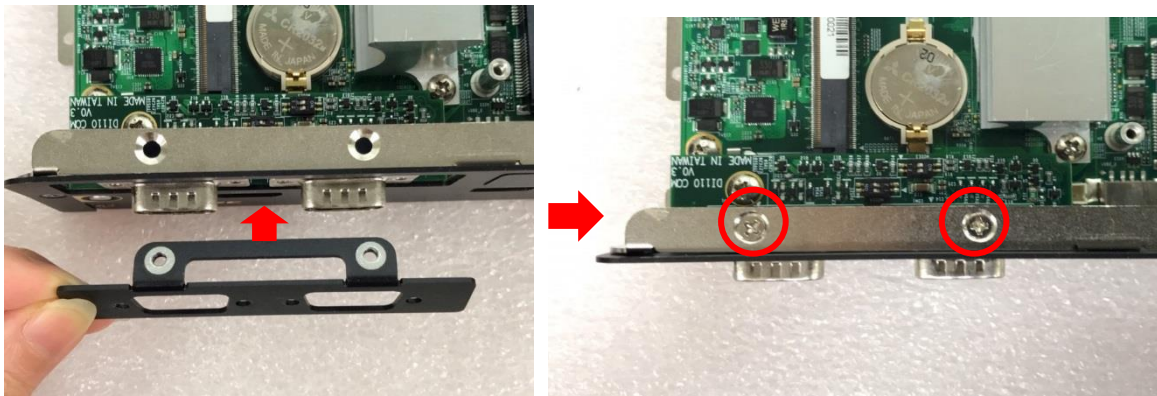

5. Fasten the 4 D-Sub jack screws to fix the module.



# 6.4 Installing CFM Module

## 6.4.1 CFM-PoE06-R10 Module

CFM-PoE06-R10 module can be installed on CMI-LAN01-R12 module, CMI-M12LAN01-R12 module or CMI-XM12LAN01-R10 module. When using CMI-LAN01-R12 module, please paste the shading tape to the place which was marked by red frame. (Watch out not to block the LED.) If you use CMI-M12LAN01-R12 module or CMI-XM12LAN01-R10 module, please skip this step.

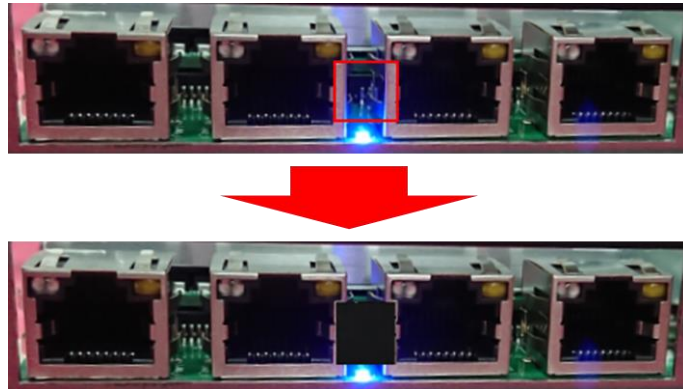

In this chapter, CMI-M12LAN01-R12 module is taken as an example to demonstrate how to install CFM-PoE06 on it. Before this chapter gets started, please execute the installation step 1 to step 4 in chapter 6.2.2 in advance.

1. Penetrate the copper pillars through the two holes on the LAN module, and fasten each copper pillar by the hex nut.

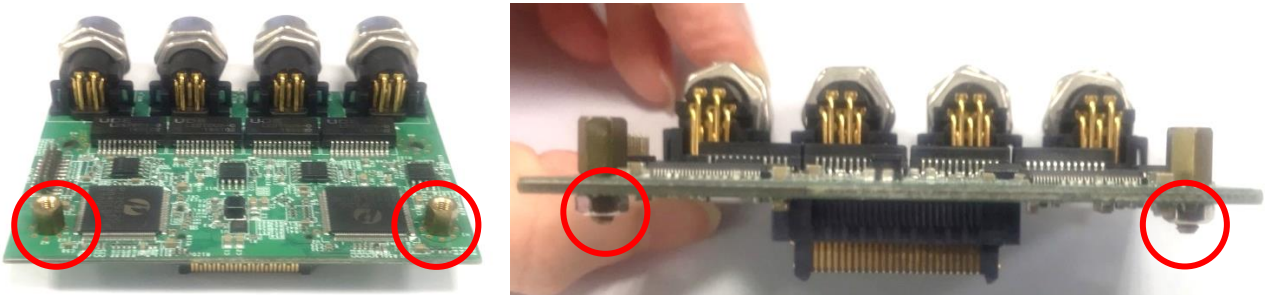

2. Insert the LAN module vertically to the female connector on system's mainboard until it is connected firmly, and fasten the two copper pillars.

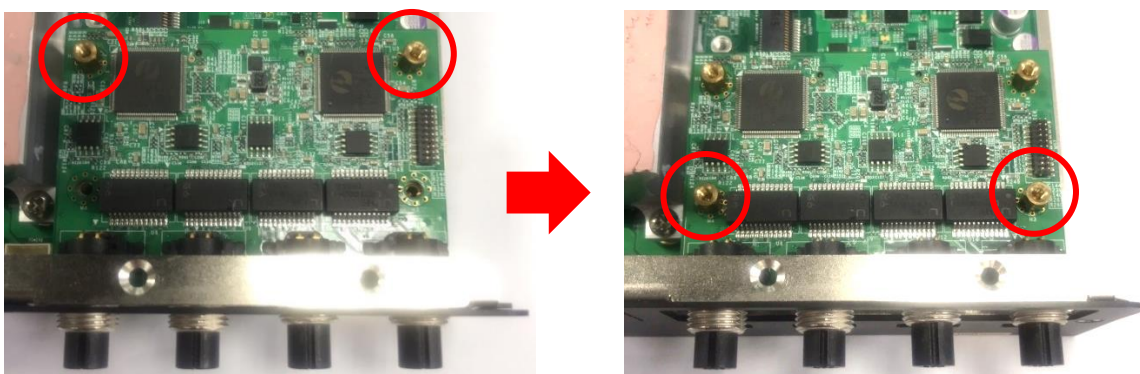

3. Insert the CFM-PoE06 module vertically into the female connector on CMI module until it's connected firmly.

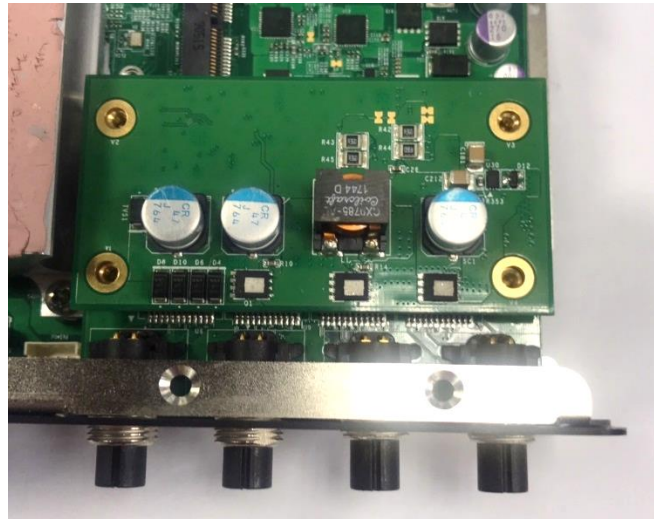

4. Turn over the heatsink of CFM-PoE06 and locate the two places marked by red squares.

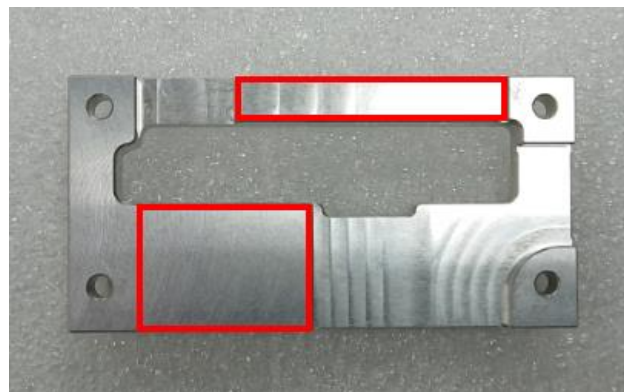

5. Paste two thermal pads for CFM-PoE06 onto the heatsink carefully.

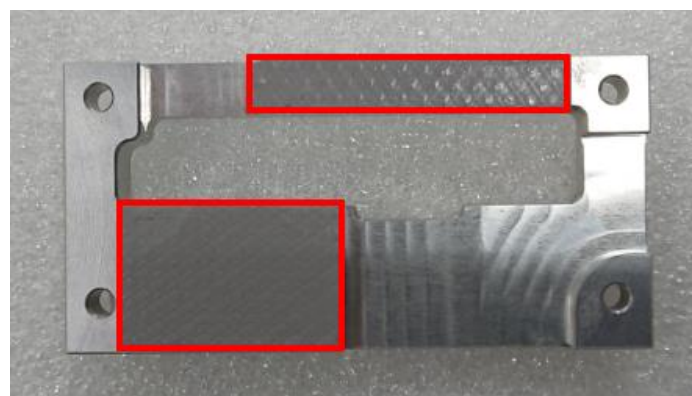

**CAUTION**

**Before putting on the thermal block (in the next step), please make sure the protective films on the Thermal Pads have been removed!**

6. Paste the heatsink onto the CFM-PoE06 module carefully, and fasten two screws to fix it.

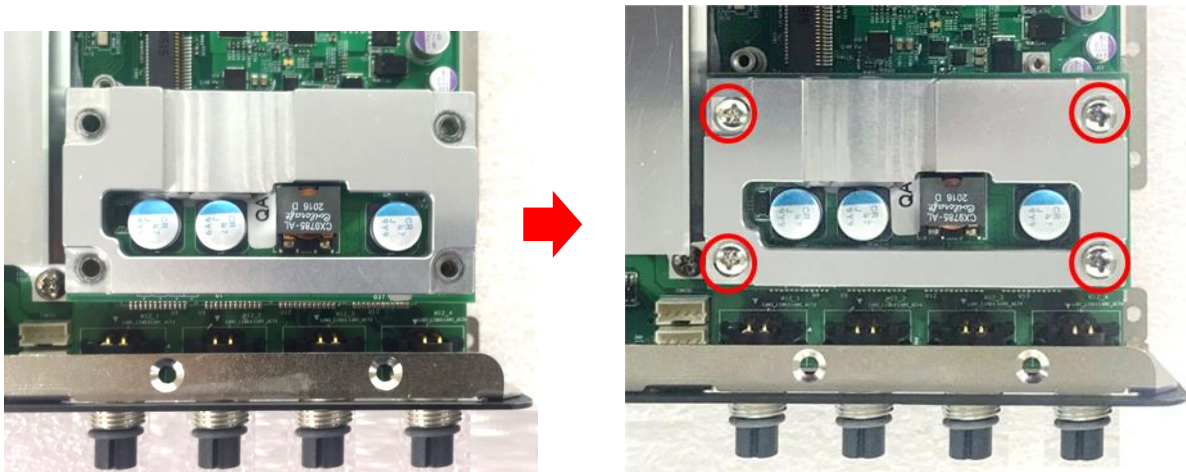

7. Paste the last thermal pad onto the heatsink carefully, and then continue the step 5~ step 6 in chapter 6.2.2.

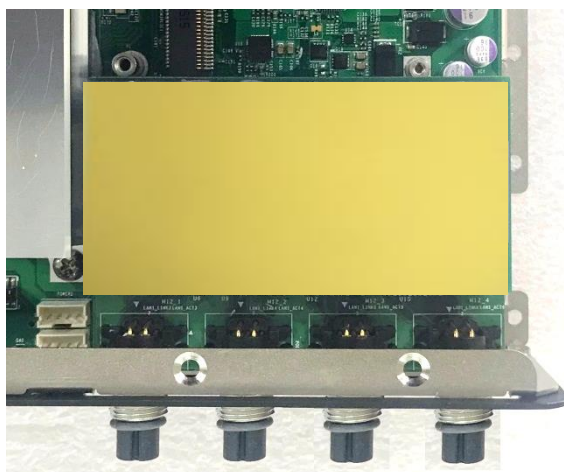

CAUTION

The yellow surface is part of the thermal pad. Do not tear it off as it would affect the thermal conductivity.

Once the steps are finished, after system power on, PoE LED (on CMI-LAN, CMI-M12 LAN, or CMI-XM12 LAN module) will light blue as shown below.



## 6.4.2 CFM-IGN102 Module

1. Locate the IGN\_PH1 connector on the bottom side of the system.

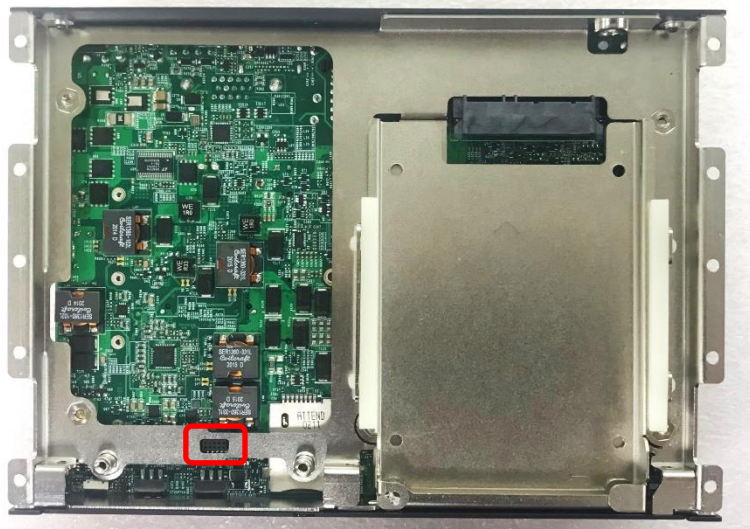

2. Insert the connector of IGN module to the female connector on system motherboard. (Make sure all the pins of IGN module's connector are firmly connected.)

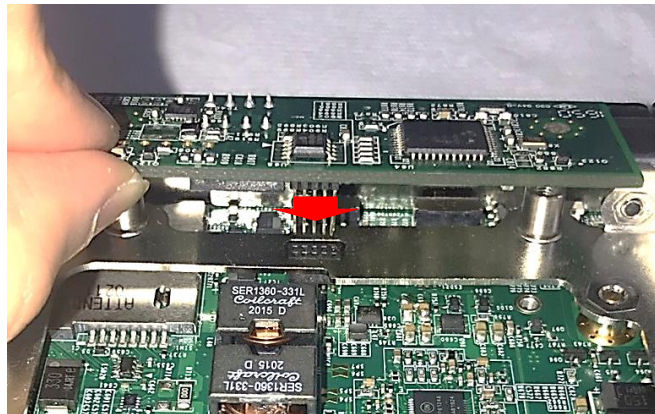

3. Fasten the two screws to secure the power ignition board.

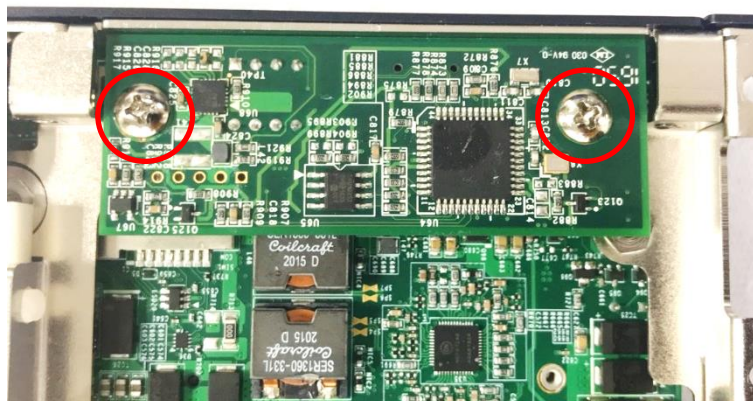

## 6.5 Installing MEC Module

### 6.5.1 MEC-LAN-M102-30/UB1511-R10 Module

1. Loosen the 2 screws on the bracket 1 (left side) or bracket 2 (right side) and then remove it.

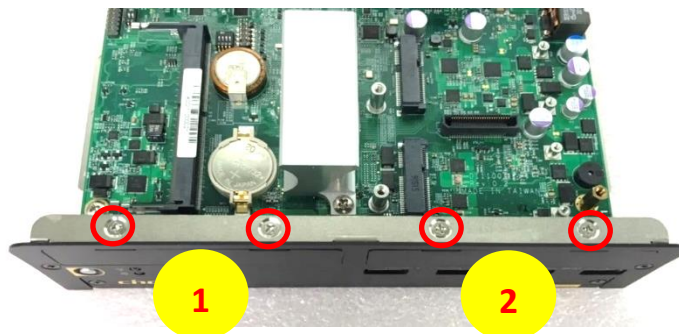

1. Attach the MEC-LAN bracket, and fasten the 2 screws to fix it as indicated.

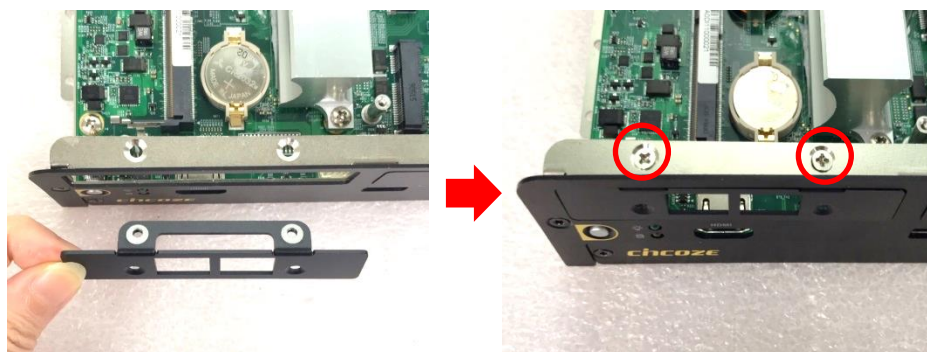

2. Locate the Mini PCIe socket(s) on the bottom side of the system.

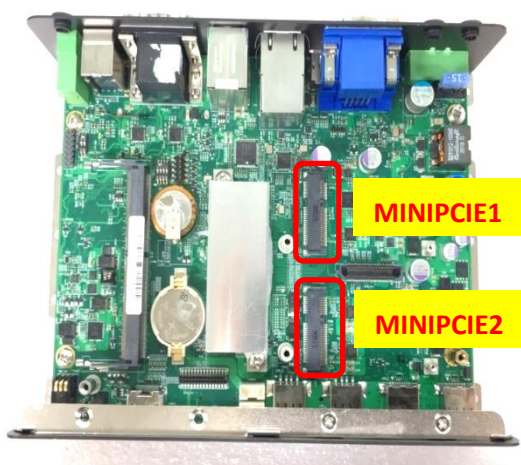

#### NOTE

When the mPCIe card is installed onto the socket MINIPCI1, then the LAN board can be installed at bracket 1 or 2. When the mPCIe card is installed onto the socket MINIPCI2, then the LAN board can only be installed at bracket 1.

3. Tilt the Mini PCIe card at a 45-degree angle and insert it to the socket until the golden finger connector of the card seated firmly.

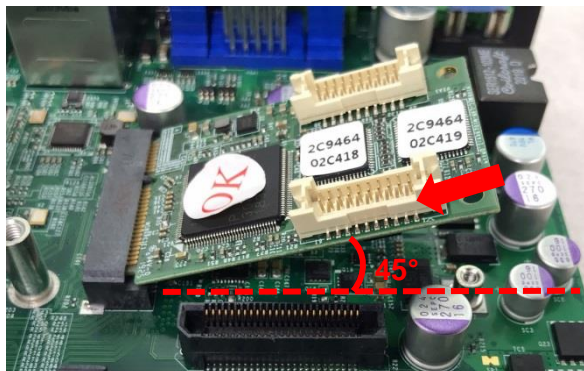

4. Press the card down and secure it with 2 screws.



5. Connect the attached wires to the LAN board.

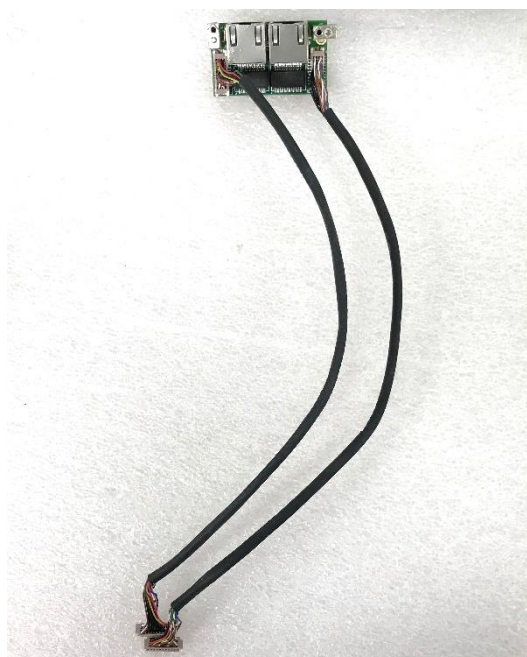

6. Connect the wires to the Mini PCIe card as indicated.

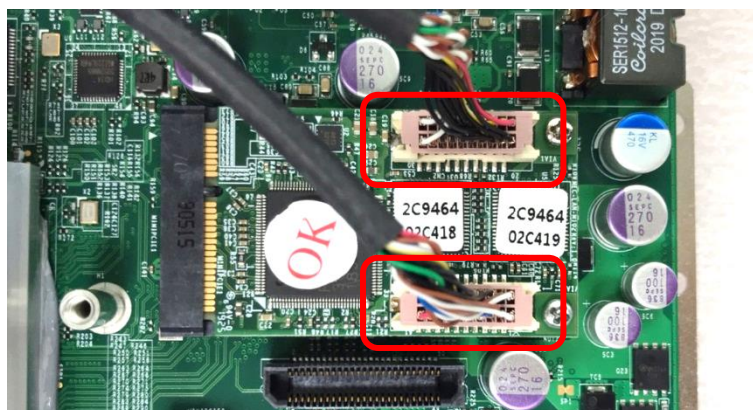

7. Attach the LAN board onto the back side of the cover plate, and then fasten the two screws to secure the module.





## 6.5.2 MEC-COM-M212-TDB9/UB1503-R10 Module

1. Loosen the 2 screws on the bracket 1 (left side) or bracket 2 (right side) and then remove it.

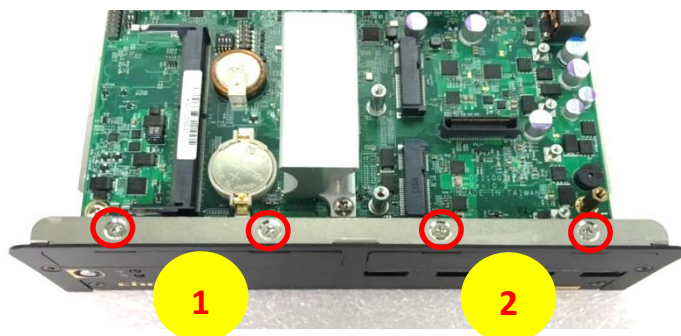

2. Attach the MEC-COM bracket, and fasten the 2 screws to fix it as indicated.

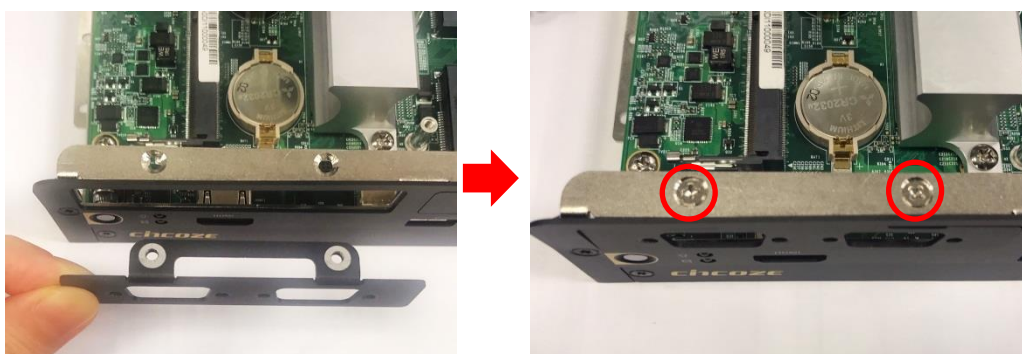

3. Locate the Mini PCIe socket(s) on the bottom side of the system.

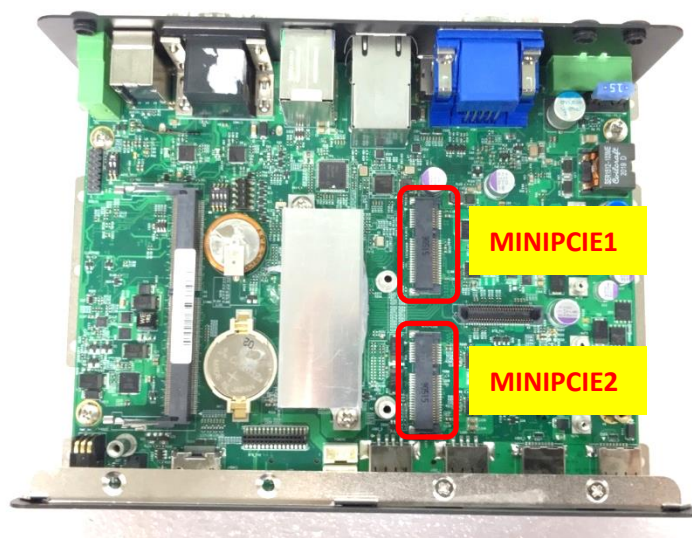

4. Tilt the Mini PCIe card at a 45-degree angle and insert it to the socket until the golden finger connector of the card seated firmly.



5. Press the card down and secure it with 2 screws.

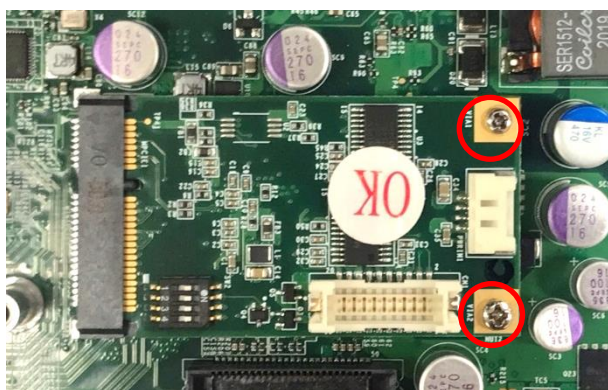

6. Remove the hex screws from the module.



7. Connect the wire to the Mini PCIe card as indicated.

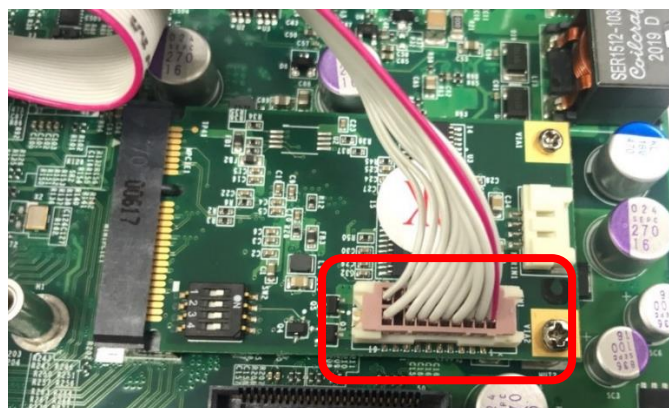

8. Penetrate the COM ports through the bracket from the back side.

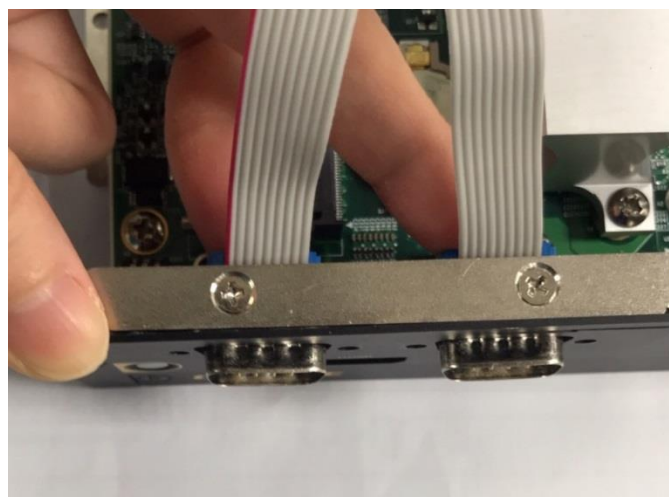

9. Fasten the hex screws back.



## 6.6 Installing External FAN



NOTE

External fan must be installed when using CFM-PoE module

### 6.6.1 FAN-EX103

1. Prepare an external fan. Loosen the 2 screws halfway on mounting frame before attempting to install it.



2. Slide the FAN into the middle groove of chassis as illustrated. Tighten the 2 screws to fix it onto chassis.

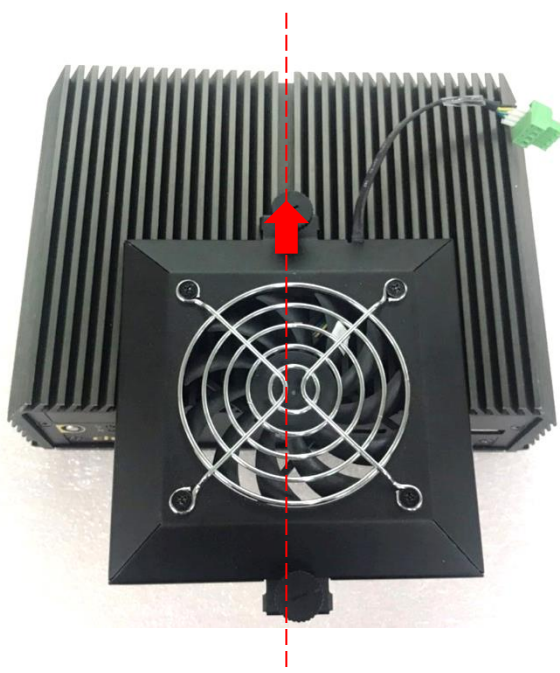

3. Move the fan to the center of chassis. Tighten the 2 screws marked on photo to secure it.



4. Connect the FAN cable to external fan power connector at rear panel.



## 6.7 Installing DIN-Rail Mount Kit

### 6.7.1 DINRAIL-R10



1. The mounting holes are at the bottom of system. Fasten the 2 screws to fix the DIN-Rail mount bracket with system together.

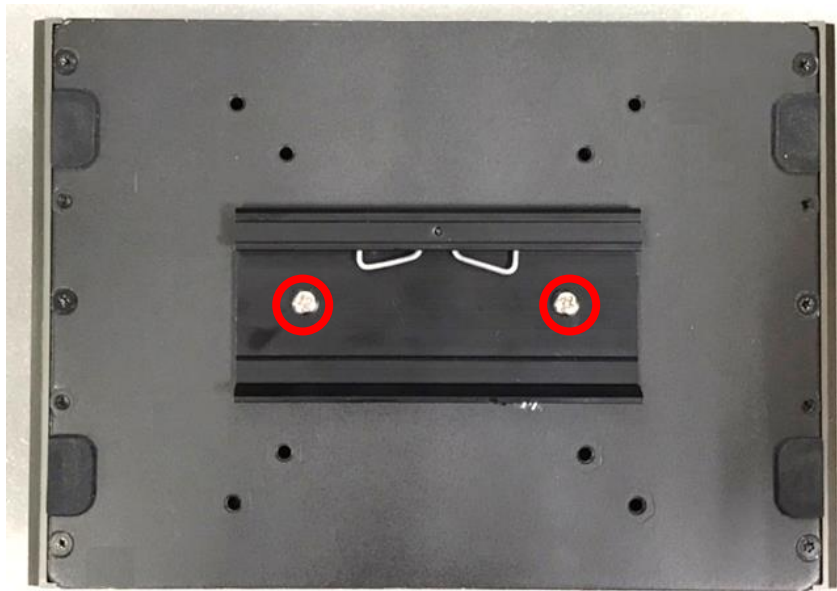

## 6.8 Installing Side Mount Kit

### 6.8.1 SIDE01



1. The mounting holes are at the bottom of system. Fasten the 4 screws to fix the side mount bracket with system together.

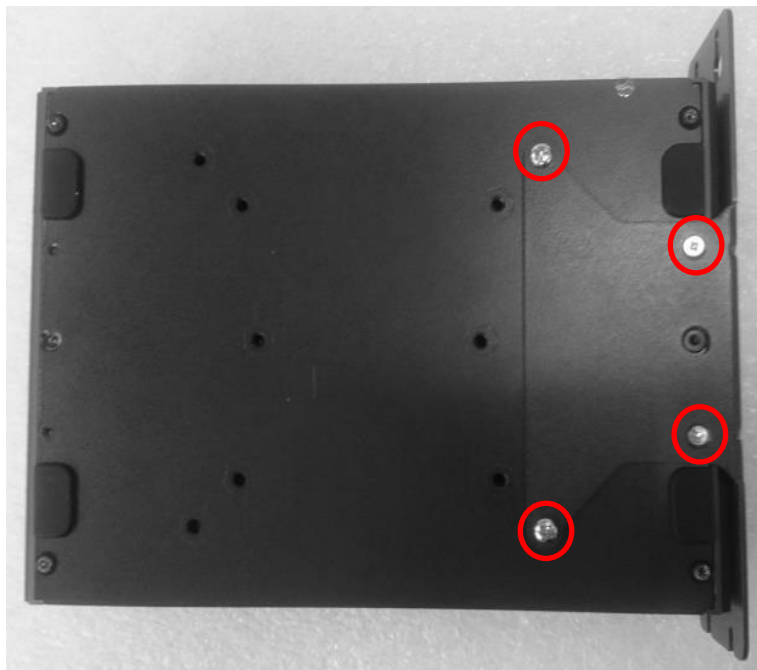

2. Fasten the screws through the bracket mounting hole to mount system on the wall.





***cincoze***

© 2021 Cincoze Co., Ltd. All rights reserved.

The Cincoze logo is a registered trademark of Cincoze Co., Ltd.

All other logos appearing in this catalog are the intellectual property of the respective company, product, or organization associated with the logo.

All product specifications and information are subject to change without notice.